

Model	Watts	Input Volt./Freq	PF	Lemen(LM)	Beam Angle	IP	CRI	Size(mm)			Warranty
VT-8600	40W↑/40W↓	100-240V/ 50/60Hz	>0.9	5200↑/3600lm↓	110°↑/90°↓	IP20	>80	610	280	1950	5years

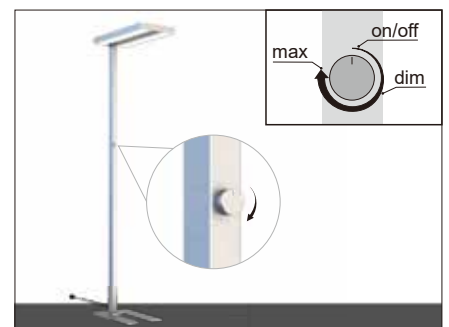
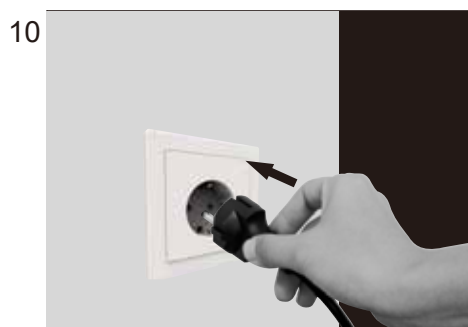
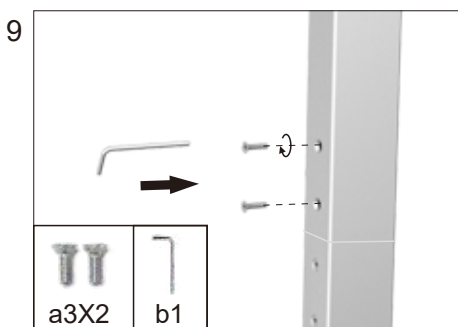
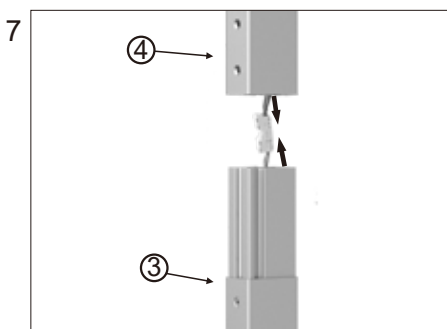
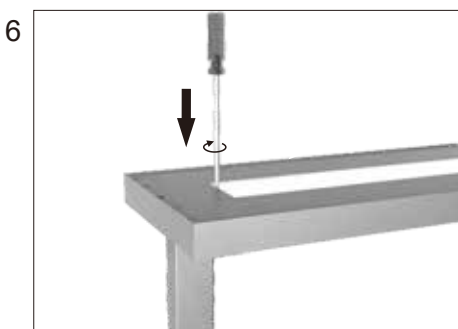
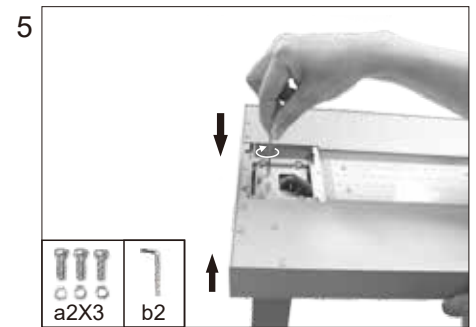
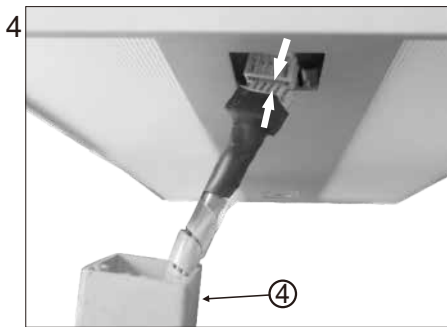
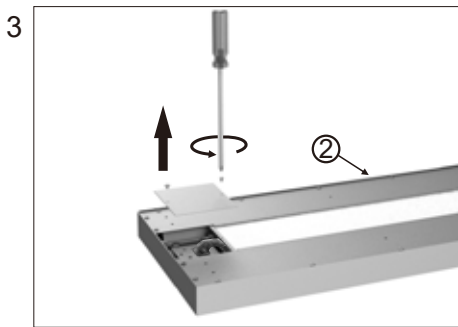
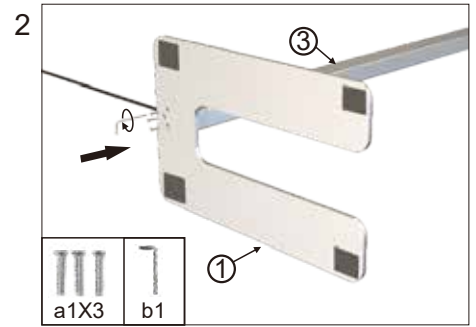
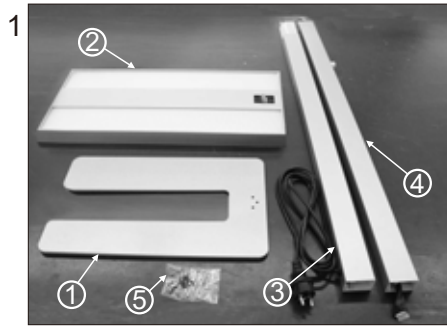
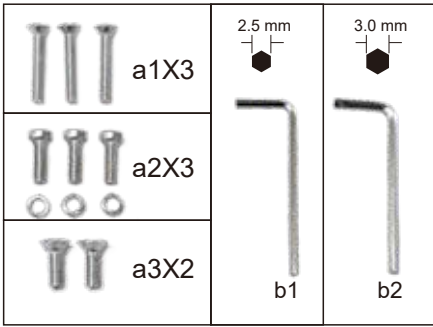

## EN Instruction&Warranty

Thank you for selecting and buying V-TAC LED product. V-TAC will serve you the best. Please read these instructions carefully before starting the installing and keep this manual handy for future reference. If you have any other query, please contact our dealer or local vendor from whom you have purchased the product. They are trained and ready to serve you at the best.

The warranty is valid for 5 years from the date of purchase. The warranty does not apply to damage caused by incorrect installation or abnormal wear and tear. The company gives no warranty against damage to any surface due to incorrect removal and installation of the product. The products are suitable for 10-12 hours daily operation. Usage of product for 24hours a day would void the warranty. This product is warranted for manufacturing defects only.

### Installation Instruction:

Step 1: please check product list as picture 1 showed. no any part lost.

- ① lamp head. ②base plate ③ ④pole  
⑤ installation kit bag.

Step 2: Fix the bottom pole onto base plate with screw a1x3

Step 3: Open the box of lamp head

Step 4: Connect the terminal block

Step 5: Fix the lamp heard with screws a2x3

Step 6: Close the box by screws

Step 7:Connect the terminal block of ③ ④

Step 8: Insert ③ into ④

Step 9: Fixed with Screw a3X2

Step 10:Power on

## BG Инструкция за монтаж:

Стъпка 1: Моля, сверете списъка с части от описанието на продукта,съгласно фиг. 1 , за да се уверите, че не е изгубена никоя част.

- ①Глава на лампата. ② Основа ③Стойка  
④ Монтажен комплект.

Стъпка 2: Фиксирайте долната част на стойката към основата, ползвайки винт a1x3

Стъпка 3: Отворете кутията на главата на лампата

Стъпка 4: Свържете лустер клемата

Стъпка 5: Фиксирайте главата на лампата с винтове a2x3

Стъпка 6: Затворете кутията и завийте винтовете

Стъпка 7: Свържете лустер клемата на ③ ④

Стъпка 8: Вкарайте ③ в ④

Стъпка 9: Фиксирайте с винт a3X2

Стъпка 10: Включете електрозахранването

## CH Pokyny pro montáž:

Krok 1: Zkontrolujte prosím seznam součástí, jak ukazuje obr. 1, abyste se ujistili, že žádná z nich se neztratila.

- ① Hlava lampy. ② Základ ③ Stojan  
④ Montážní sada.

Krok 2: Upevněte spodní část stojanu k desce základu pomocí šroubu a1x3

Krok 3: Otevřete krabici na hlavě lampy

Krok 4: Připojte lustrsvorku

Krok 5: Zafixujte hlavu lampy šrouby a2x3

Krok 6: Zavřete krabici a utáhněte šrouby

Krok 7: Připojte lustrsvorku k ③ ④

Krok 8: Vložte ③ do ④

Krok 9: Upevněte šroubem a3X2

Krok 10: Zapněte napájení.

## DE Installationsanleitung:

Schritt 1: Bitte überprüfen Sie die Produktliste wie in Bild 1 gezeigt, um sicher zu stellen, dass kein Teil verloren worden ist.

- ①Lampenkopf. ②Sockelplatte ③Stange  
④Installationsset.

Schritt 2: Befestigen Sie den unteren Teil der Stange an der Sockelplatte mit Schraube a1x3

Schritt 3: Öffnen Sie die Schachtel des Lampenkopfs

Schritt 4: Schließen Sie den Klemmenblock an

Schritt 5: Befestigen Sie den Lampenkopf mit Schrauben a2x3

Schritt 6: Schließen Sie die Schachtel mit Schrauben

Schritt 7: Schließen Sie den Klemmenblock von ③ ④an

Schritt 8: Stecken Sie ③in ④ein

Schritt 9: Fix mit Schraube a3X2

Schritt 10: Einschalten

## ES Instrucciones de instalación:

Paso 1: Por favor, verifique la lista de las piezas de la descripción del producto de acuerdo con fig. 1 para asegurarse de que ninguna pieza esté perdida.

- ① Cabeza de lámpara. ② Base ③ Soporte  
④ Kit de montaje.

Paso 2: Fije la parte inferior del soporte a la base con el tornillo a1x3

Paso 3: Abra la caja de la cabeza de la lámpara

Paso 4: Conecte la ficha de empalme

Paso 5: Fije la cabeza de la lámpara con tornillos a2x3

Paso 6: Cierre la caja y apriete los tornillos

Paso 7: Conecte la ficha de empalme en ③ ④

Paso 8: Introduzca ③ en ④

Paso 9: Arregle con el tornillo a3X2

Paso 10: Encienda la fuente de alimentación

## FR Instruction d'installation:

Étape 1: Veuillez vérifier la liste des pièces de la description du produit comme indiqué sur l'image 1 afin de vous assurer qu'aucune pièce n'est perdue.

- ① tête de lampe. ② base ③ support  
④ kit d'installation.

Étape 2: Fixez le poteau inférieur sur la plaque de base au moyen de la vis a1x3

Étape 3: Ouvrez la boîte de la tête de la lampe

Étape 4: Connectez la plaque à bornes

Étape 5: Fixez la tête de la lampe au moyen des vis a2x3

Étape 6: Fermez la boîte serrez les vis

Étape 7: Connectez la plaque à bornes ③ ④

Étape 8: Insérer ③ dans ④

Étape 9: Fixer avec la vis a3X2

Étape 10: Mettez sous tension

## GR Οδηγίες για την τοποθέτηση:

Βήμα 1: Παρακαλώ, ελέγξτε τον κατάλογο των εξαρτημάτων του προϊόντος στην περιγραφή του, σύμφωνα με το σχεδιάγραμμα 1, για να βεβαιωθείτε ότι δεν έχει χαθεί κανένα εξάρτημα.

- ① Κεφαλή της λάμπας. ② Βάση. ③Στήριγμα  
④ σετ τοποθέτησης.

Βήμα 2: Συνδέστε το κάτω μέρος του στηρίγματος στη βάση, χρησιμοποιώντας τη βίδα a1x3.

Βήμα 3: Ανοίξτε το κουτί της κεφαλής της λάμπας.

Βήμα 4: Συνδέστε το looster στήριγμα.

Βήμα 5: Ακινητοποιήστε την κεφαλή της λάμπας με βίδες a2x3.

Βήμα 6: Κλείστε το κουτί και βιδώστε τις βίδες.

Βήμα 7: Συνδέστε το looster στήριγμα σε ③ ④.

Βήμα 8: Χώστε το ③ στο ④.

Βήμα 9: Βιδώστε με βίδα a3X2

Βήμα 10: Συνδέστε την ηλεκτροδότηση.

## HRV Upute za montažu:

Korak 1.: Molimo, provjerite popis dijelova u opisa proizvoda, sukladno sa slikom 1, kako biste bili sigurni da nijedan dio nije izgubljen.

- ① glava svjetiljke. ② Temelj ③Postolje  
④ Komplet za montažu.

Korak 2.: Pričvrstite donji dio postolja na temelj, pomoću vijka a1x3

Korak 3.: Otvorite kućište na glavi svjetiljke

Korak 4.: Spojite stezaljku (luster-klemu)

Korak 5.: Pričvrstite glavu svjetiljke s vijcima a2x3

Korak 6: Zatvorite kutiju i pričvrstite vijke

Korak 7: Spojite stezaljku (luster-klemu) od ③ ④

Korak 8: Umetnite ③ u ④

Korak 9: Popravite vijkom a3X2

Korak 10: Uključite napajanje strujom

## HU Szerelési utasítások:

1. lépés: kérjük, ellenőrizze a terméklistát, ahogy a 1. ábra mutatja ki. nem elveszett-e valamilyen alkatrész.

- ① lámpafej. ② alapelem ③ állvány  
④ szerelési készlet.

2. lépés: Rögzítse az állvány alsó részét az alapelemhez a1x3-es csavarral

3. lépés: Nyissa ki a lámpafej dobozát

4. lépés: Csatlakoztassa a kapocsblokkot

5. lépés: Rögzítse a lámpafejet a2x3-as csavarokkal

6. lépés: Zárja le a dobozt csavarokkal

7. lépés: Csatlakoztassa a kapocsblokkot ③ ④-re

8. lépés: Helyezze be a ③-t ④-be

9. lépés: Rögzítse az a3X2 csavarral

10. lépés: Bekapcsolás

## IT Istruzioni per il montaggio:

Passo 1: Si prega di confrontare l'elenco delle parti della descrizione del prodotto in conformità a fig. 1, per assicurarsi che non manca qualche parte.

- ① Testa della lampada. ② Piastra di base  
③ Stelo ④ Kit di montaggio.

Passo 2: Fissare la parte inferiore dello stelo alla base utilizzando la vite a1x3

Passo 3: Aprire la scatola della testa della lampada

Passo 4: Collegare la morsettiere

Passo 5: Fissare la testa della lampada con le viti a2x3

Passo 6: Chiudere la scatola e avvitare le viti

Passo 7: Collegare la morsettiere a ③ ④

Passo 8: Inserire ③ nel ④

Passo 9: Fissare con vite a3X2

Passo 10: Accendere

## RO Instrucțiuni de montaj:

Passul 1:Vă rugăm să verificați lista cu piesele care se conțin în descrierea produsului, în conformitate cu fig. 1, ca să vă asigurați că nimic nu a fost pierdut.

- ①Capul lămpii. ② Baza ③Suportul  
④ Accesorile de montaj.

Passul 2: Fixați partea inferioară a suportului de baza lămpii, folosind șurubul a1x3

Passul 3: Deschideți carcasa capului lămpii

Passul 4: Legați clema lustrei

Passul 5: Fixați capul lămpii cu ajutorul șuruburilor a2x3

Passul 6: Închideți carcasa și înșurubați șuruburile

Passul 7: Legați clema lustrele ③ ④

Passul 8: Introduceți nr.③ în ④

Passul 9: Fixați cu șurubul a3X2

Passul 10: Conectați alimentarea cu energie electrică

In case of any query/issue with the product please reach out to us at:  
support@v-tac.eu

For More products range, inquiry please contact our distributor or nearest dealers.  
V-TAC EUROPE LTD  
Bulgaria, Plovdiv 4000, bul.L.Karavelov 9B