

## Table of Contents

<b>Table of Contents</b> .....	01
<b>Chapter1 Model801, Model802 Functions and Features</b> .....	03
1.1 New Functions of the Eighth Generation Cards.....	03
1.2 Functions and Features of the Eighth Generation Cards .....	03
<b>Chapter2 Linsn Control System Installation Instruction</b> .....	07
Sending card. ....	07
<b>Power Supply</b> .....	07
<b>Communication Cable</b> .....	07
<b>DVI transmission Cable</b> .....	07
<b>Network cable RJ45 transmission cable (568B-to-568B or 568A-to-568A)</b> .....	08
Receiving card . ....	09
<b>Power supply:</b> .....	09
<b>Network cable RJ45 transmission cable (568B-to-568B or 568A-to-568A)</b> .....	09
<b>50-pin outputs</b> .....	10
<b>Chapter3 Setup</b> .....	12
1. Enter Setup. ....	12
2. Sender setup. ....	14
Settings:.....	14
Other Details: .....	14
3. Receiver setup. ....	18
3.1 Settings. ....	18
3.2 Other details: . ....	18
3.3 How to run intelligent setup. ....	22
3.3.1 Preparation .....	22
3.3.2 Input LED Module Information .....	22
3.3.3 Watch and Select .....	25
3.3.4 Setup Other Parameters .....	28
4. Led Display Connection Setup. ....	29
4.1 Settings. ....	29
4.1.1 Set mode: Normal .....	29
4.1.2 Display QTY: .....	29
4.1.3 Input each receiving card info .....	30
4.1.4 Input each receiving card info .....	31
4.2 Examples: .....	31
<b>Chapter4 Brightness Correction</b> .....	33
4.1 Camera Brightness Correction. ....	33
4.1.1 General. ....	33
4.1.2 Preparations. ....	34
4.1.3 Steps of Brightness Correction. ....	38
4.1.3.1 Click Screen area color correction, select Photo partition.....	38
4.1.3.2 Click from camera, Select Cr. Mode and Ms. Mode, click Preview .....	40
4.1.3.3 Click Preview .....	41

4.1.3.4 Start Demarcate, .....	41
4.1.3.5 Whole LED Display Brightness Correction. ....	42
4.1.3.6 Fact brightness . ....	43
4.2 Manual Brightness Adjustment .....	44
<b>Chapter5 Communication Cable Making Method. ....</b>	<b>49</b>

## Chapter1 Model801, Model802 Functions and Features

### 1.1 New Functions of the Eighth Generation Cards

#### 1. High refresh rate, high gray level for constant current driver IC

Add Grey mode options, High Refresh Mode refresh rate can be 8-128 times higher than Standard Mode, and grey level reaches 65536

#### 2. Increasing software brightness correction size

Increasing single receiving card from 96X64, to 320X256, make the brightness correction on big led display Time-effective

#### 3. Supporting PWM driver IC

Supports MBI5030, MBI5042, DM13H, TC62D722 and so on

#### 4. Enhanced utility on receiving card 50-pin output

Each 50-pin output of receiving card has 8 groups of RGB signals. For cabinets applied within 8 groups of RGB signals, receiving card is optimized for better refresh rate and grey level.

#### 5. Receiving card adjustable Start X

One receiving card has 16 groups of RGB signals, and each groups of RGB signal can be set different Start X. This is applied for some special shape led display.

#### 6. Sending card U/D port flexibility for carrying half width or half height

For example, TS801 can max support 1280\*1024 with two ports  
A single network output port supports 1280\*512 or 640X1024

#### 7. LED display gradually light-up function

Note: 801D card can be upgraded. Upgrade receiving card 801D adding new functions of point 1,2,3,4,5,7;

Upgrade sending card 801D, 802D adding new function of point 6.

Require LedStudio11.10 or above.

### 1.2 Functions and Features of the Eighth Generation Cards

#### 1. Completely Compatible with the Seventh Generation Control System

The eighth generation is developed based on the seventh. Compared with the seventh, the eighth has all the functions of the seventh. Moreover, the eighth is more functional, more powerful, more stable and more reliable.

#### 2. Supporting $2^{10}$ colors

The seventh supports  $2^8$  colors:  $2^8 * 2^8 * 2^8 = 16777216$  kinds of colors.

The eighth supports  $2^{10}$  colors:  $2^{10} * 2^{10} * 2^{10} = 1073741824$  kinds of colors. It needs to work with our video processors using the 30 bits TTL.

So the coloring number of the eighth is 64 times as much as that of the seventh.

### **3. The intelligent connecting function**

Without resetting the configurations, the receiving cards (including spare ones) of the same LED display/cabinet can be randomly exchanged or replaced, for they will automatically recognize the showing area and content they are responsible for.

### **4. The intelligent supervision function**

In each receiving card, there is a temperature sensor and four fan-power-output-ports. The speed of the fans is under wise controlled according to the warming value of temperature set by users.

### **5. Company Logo Showing**

If the power of the sending card is not turned on, the monitor the PC will automatically show the preset company picture. The pixel of the picture will be 128\*128, the coloring number 16K.

### **6. Supporting more scan mode**

The seventh supports 1, 2, 4, 8, 16 scan mode, the eighth supports 1, 2, 3, 4, 5, 6, 7, 8, 9, 10, 11, 12, 13, 14, 15, 16 scan mode.

### **7. Supporting more modules**

The seventh supports modules with the width: 2pixels, 4 pixels, 8 pixels, 16 pixels, 32 pixels, 64 pixels.

The eighth supports all the modules with width within 64 pixels. That is from 1 pixel to 64 pixels.

### **8. Supporting cut-up function**

Each receiving card max supports 1024 pieces cutup, for non-conventional type display or text display use.

### **9. supporting empty pixel insert**

The eighth can be set to insert one or more empty pixels every X pixels. This function is applying in non-conventional type display.

### **10. Supporting PWM driver chip**

Need to use particular driver chip

Make the display effect going perfect

### **11. Supporting hardware pixel by pixel correction**

Need to use particular driver chip. By changing the current for the LED, adjust the color, wave and brightness of the LED.

Make the effect of display pixel by pixel correction better.

### **12. Supporting pixel supervision function**

Need to use particular driver chip

Dynamically check the bad pixels on the display.

### **13. Giga Technology**

Veritable Giga technology. One sending card can support the max pixels: Model801: 1280\*1024; model802: 2048\*640; two cards are cascaded: 2048\*1152. Single network cable supports the max pixels: Model801: 1024\*640, 1280\*512; Model802: 1600\*400, 2048\*320

### **14. Pixel by Pixel Correction and Unit box by Unit box Correction Function**

Pixel by pixel correction supports four kinds of correction modes: single pixel,



2\*2pixels, 4\*4 pixels, 8\*8 pixels; and the max correction is 6144 pixels/module, and brightness 256 levels for red, green, blue. Every unit box correction is used to adjust the chromatism among every unit box; and brightness 256 levels for red, green, blue.

#### **15. Intelligent Identification Function**

The intelligent identification program can recognize every kind of scanning mode and every type of signal trend of all kinds of double-color, full-color (real pixel and virtual pixel) drive boards, and the accuracy rate is 99%.

#### **16. Gray level 0---Gray Level 66536 (64K) are User adjustable**

Users can adjust the gray level from 0 to 66536 levels according to requirement of displays, making the display achieve the most desirable effects.

#### **17. User adjustable Refresh Frequency, Synchronous function**

Refresh frequency are adjustable from 10HZ to 3000HZ, and the refresh frequency and phase-lock function can make the display refresh locked at integral multiple of that of computer display, avoiding the image to be torn, and ensuring the image to be perfect. The phase-lock synchronous range is from 47HZ to 76HZ.

#### **18. Super loading capacity**

Full-color receiving card with gray level 4096 (Model 4K) and refresh frequency 180HZ can support 512\*128; full-color receiving card (Model 16K, only for static) with gray level 16384 and refresh frequency 300HZ can control 160\*64,(Remarks: the drive board must realize high frequency 30MHZ)

#### **19. Double network cables switch automatically**

The A and B ports of the receiving card can be both used as input ports or output ports. Users can adapt two computers to control a display at the same time, when one is out of order, the other will replace it automatically; Users can also use one computer with double network cables to control a display, when one is out of order, the other will take place of it automatically, making the display work normally all time.

#### **20. Multi-display synchronous and combination functions.**

Supporting one sending card to control multi-display, and the multi-display can be willful combination, synchronous display, and independent play.

#### **21. 256 Levels Automatic Brightness Regulation**

The function of 256 levels automatic brightness regulation can make the display brightness regulation more efficient.

#### **22. Audio Transmission Function**

Model 802 integrates the audio transmission, and requires no audio cable to transmit audio signals to the display. Double 24bits and 64KHZ hi-fi digital analogy and modulus switch to transmit the voice, making display achieve the perfect video effect.

#### **23. Upgrade Program Online**

If program of receiving card needs to be upgraded, just open the display power, and upgrade it through Led Studio, no need to remove the receiving card from the display.

#### **24. No Toggle Switch**

No toggle switches on the receiving card, all the setups are set through Led

Studio.

**25. Test Function**

Receiving card has the test function, no sending card needed; can test the display directly, such as bias, gray level, red, green, blue, etc.

**26. Super Long Transmission Distance**

The max transmission distance is 170M (actual measure); normal transmission distance is 140M.

**27. Matching software**

Led Studio V9.0 or above.

**Remarks:**

Sending card includes: full-color TS801, full-color TS802, double-color DS 801, double-color DS802

**The differences between full-color system and double system:** double-color sending card can only be used for double-color display and single color display, but full-color sending card is suitable both for full-color (real pixel and virtual pixel) and double-color displays; however, double-color receiving card is the same as the full-color one.

**The differences between model 801 sending card and model 802 sending card:**

Model801 can max support 1280\*1024pixels

Model802 can max support 2048\*1152pixels

Single card model 802 can control 2048\*640pixels

Model802 has been added the audio transmission and cascade functions

## Chapter2 Linsn Control System Installation Instruction

### Sending card

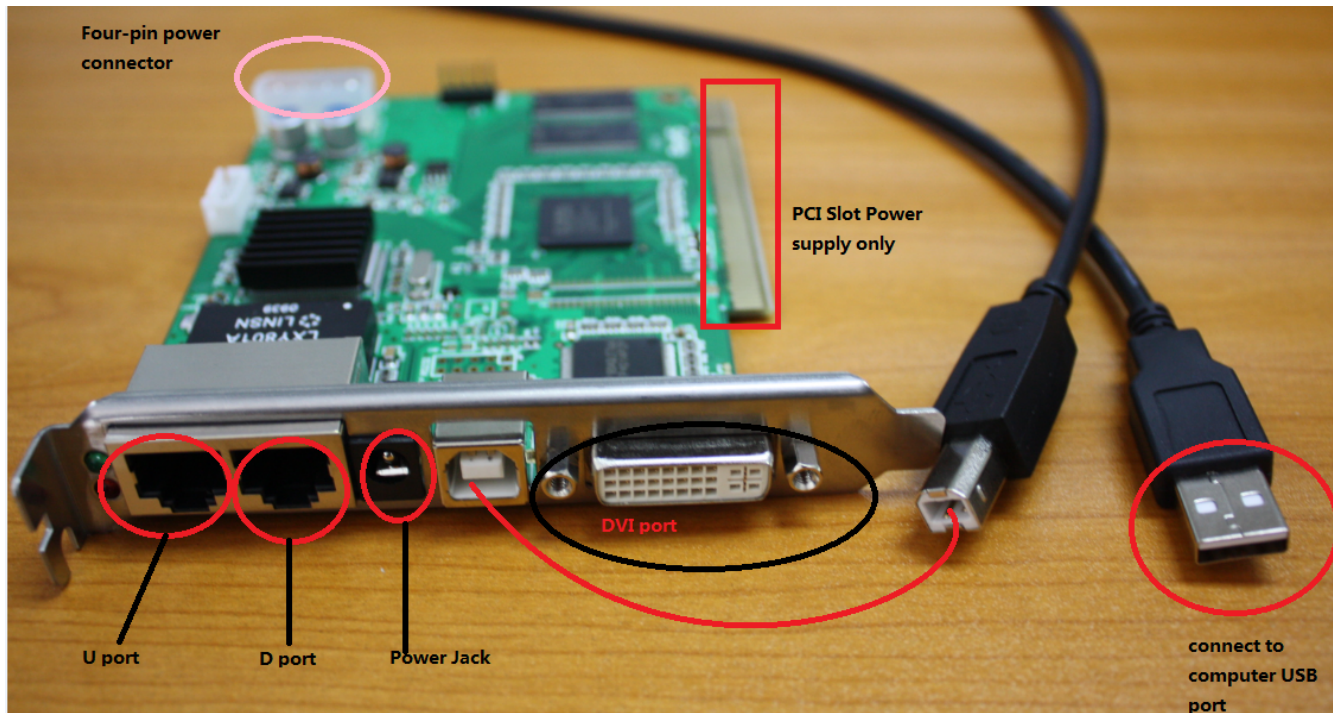

### Power Supply

**Methods:** by Four-pin power connector/PCI slot Power supply/Power Jack (the middle pin of power jack is positive; the first pin of the four-pin power connector is positive, the fourth pin is near the PCI slot)

**Specs:** DC, 5V-6.3V, 2A

### Communication Cable

Connecting the sending card USB-B port and the computer USB-A port

### DVI transmission Cable

DVI cable: Connecting the sending card DVI port and the **DVI-D** port of computer graphics card  
Set the DVI output of computer graphics card to **CLONE** mode, so the sending card is copying the content on computer monitor to LED Display

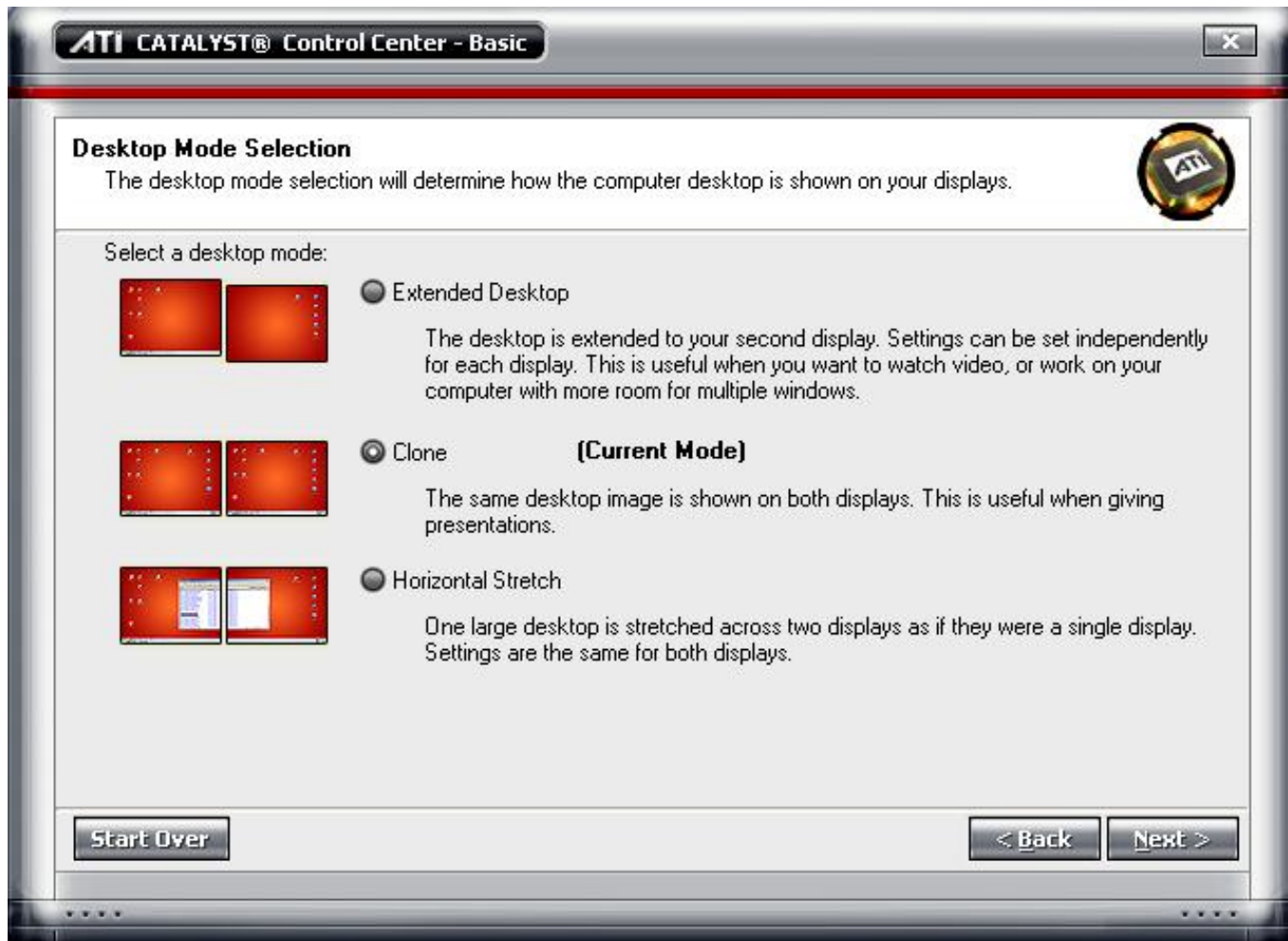

## Network cable RJ45 transmission cable (568B-to-568B or 568A-to-568A)

U port means Upper port; it carries the upper half of the height

D port means Down port; it carries the lower half of the height

For example: TS801D sending card, in 1280\*1024 resolution mode,

U port carries 1280\*512 (Start Y: 0-512)

D port carries 1280\*512 (Start Y: 513-1024)

After installation:

The LED indicators of sending card will be **RED light on**, and **GREEN light flashing**.

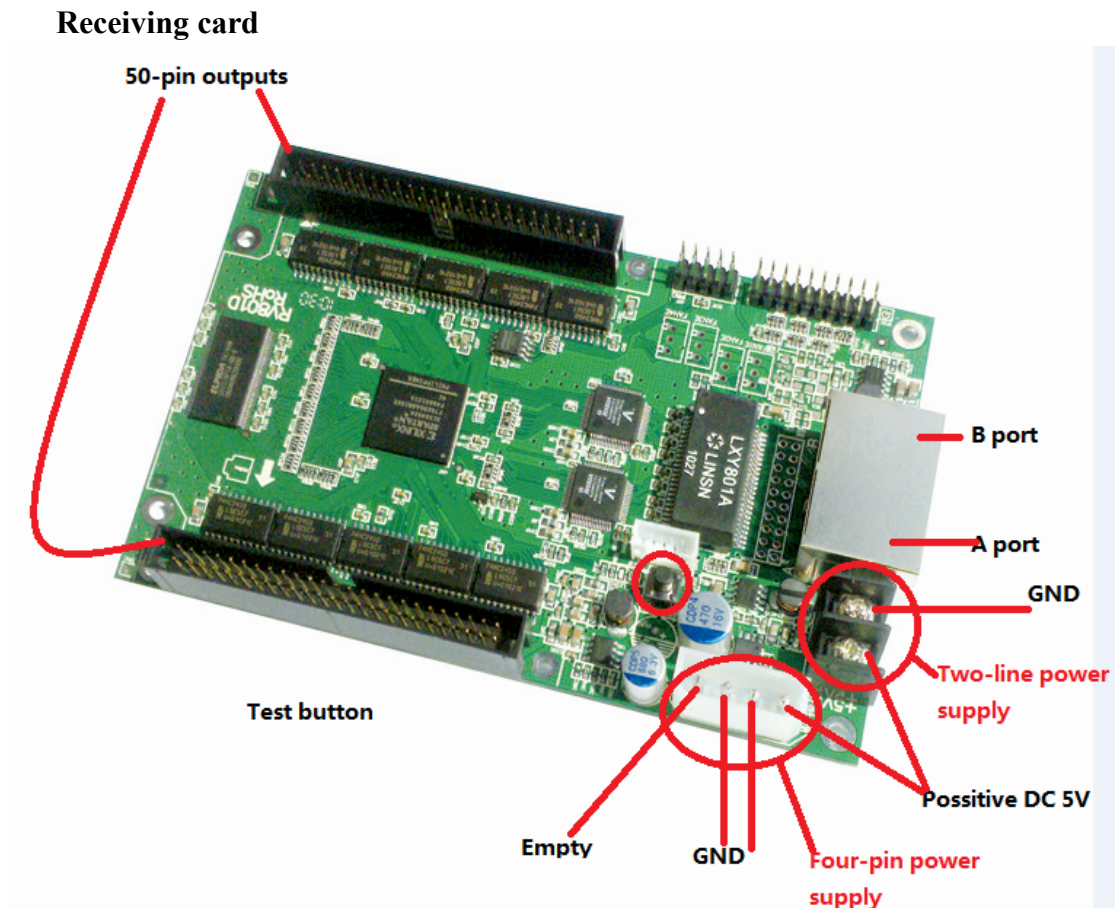

### Power supply:

DC, 3.3-5V, 2A; by two-line power supply/Four-pin power supply

### Network cable RJ45 transmission cable (568B-to-568B or 568A-to-568A)

Usually, A port gets input signals from sending card U port/D port  
 B port outputs signals to the next receiving card A port  
 In short, we call **A in B out**

After installation:

The LED indicators of receiving card will be **RED** light on, and **GREEN** light flashing.  
**When A in B out, green light flashing fast; when B in A out, green light flashing slowly**



## 50-pin outputs

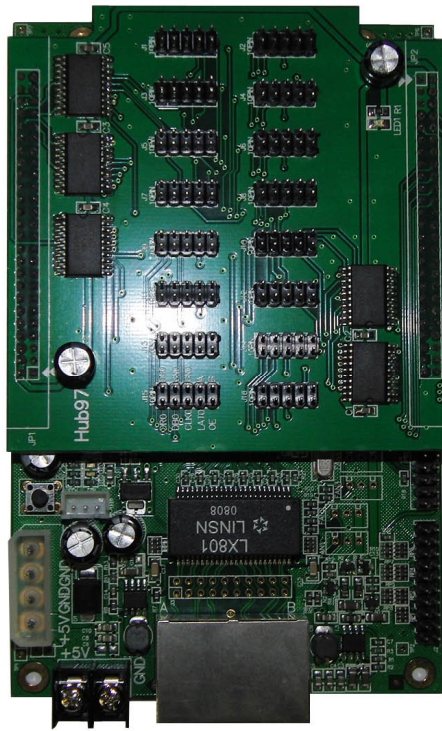
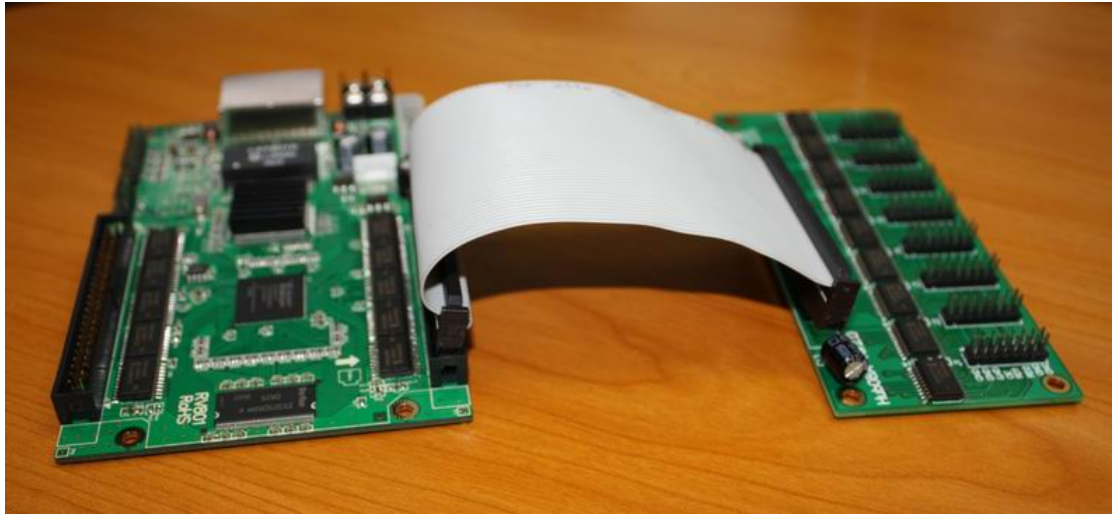

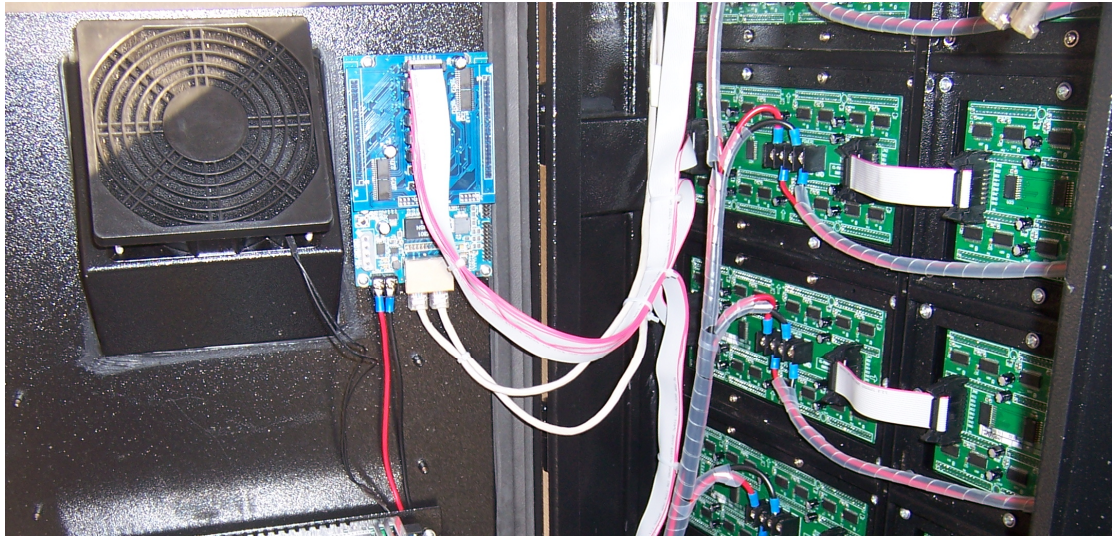

## Chapter3 Setup

Set the Linsn LED Display Control System to work with LED Display.

### 1. Enter Setup

LedStudio, Option, Software Setup;

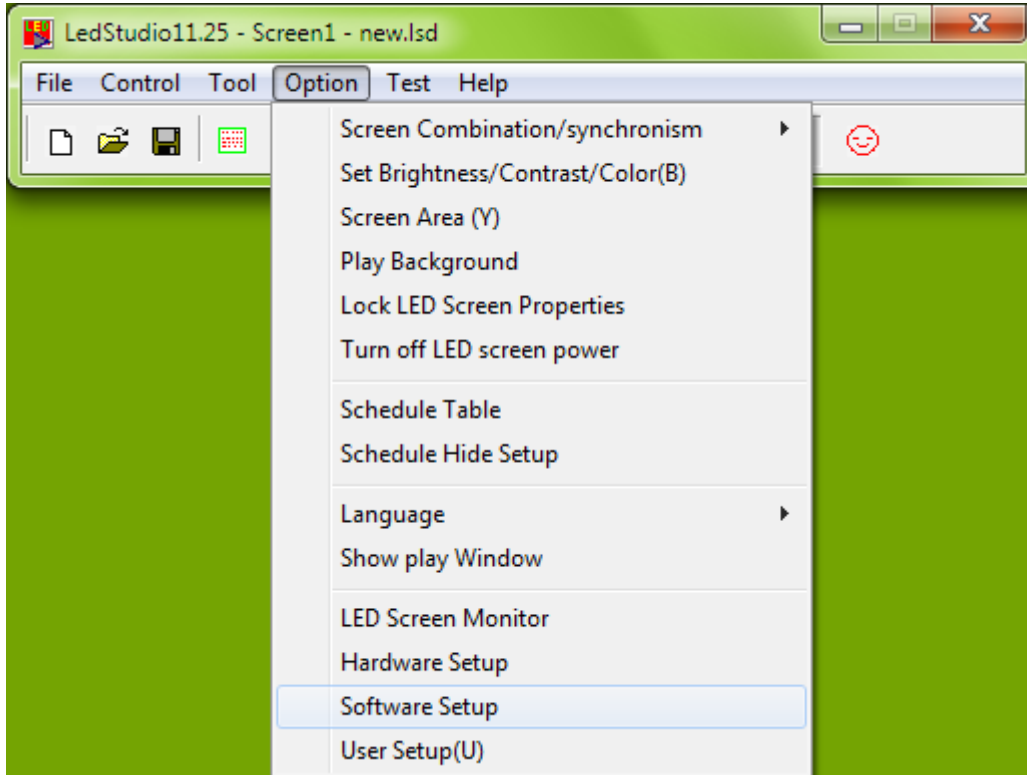



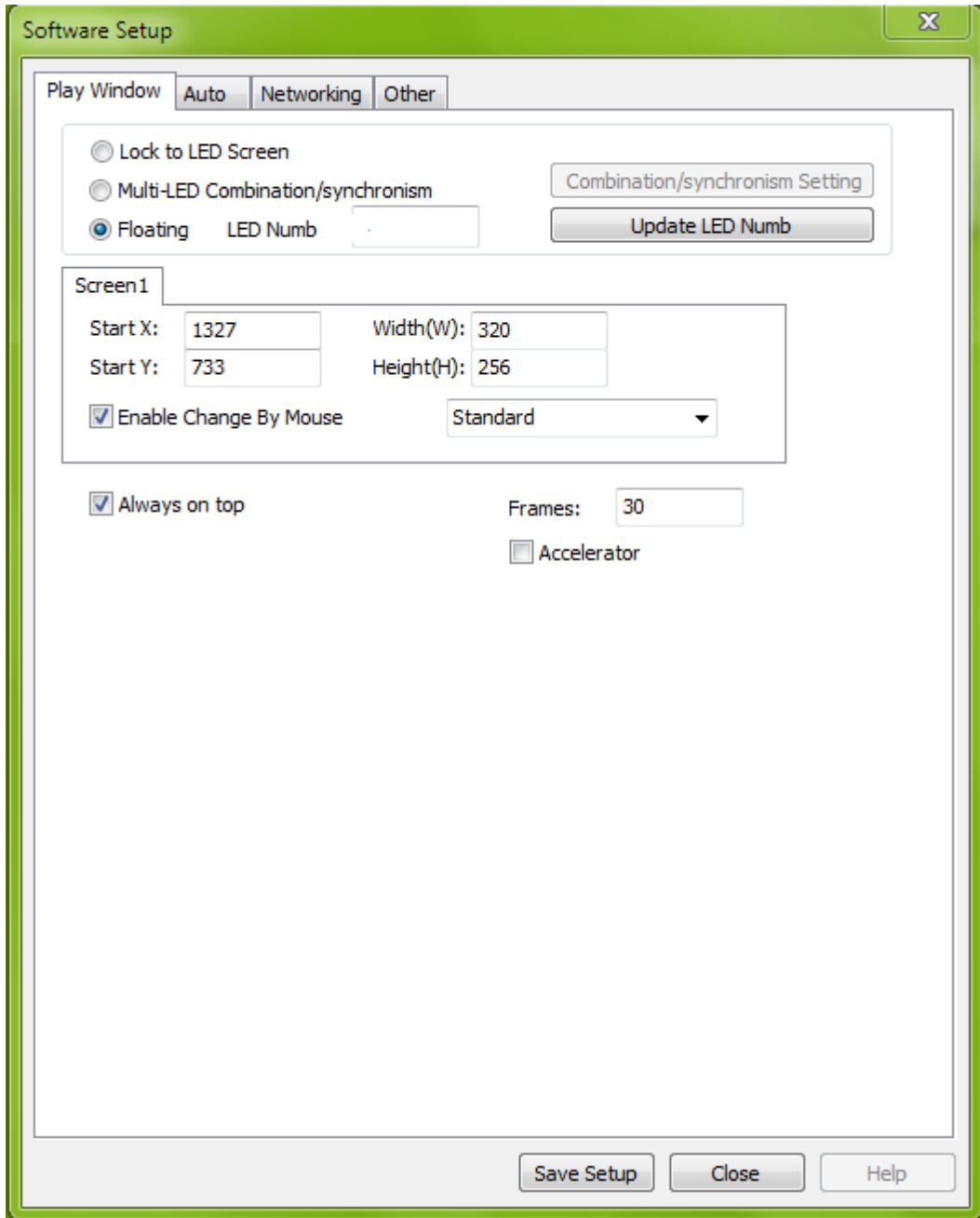

Click anyplace that allows type in or just knock at keyboard “linsn”,

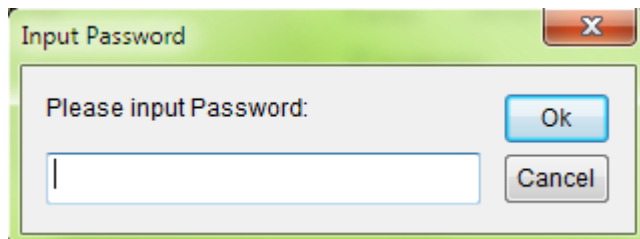

Password 168

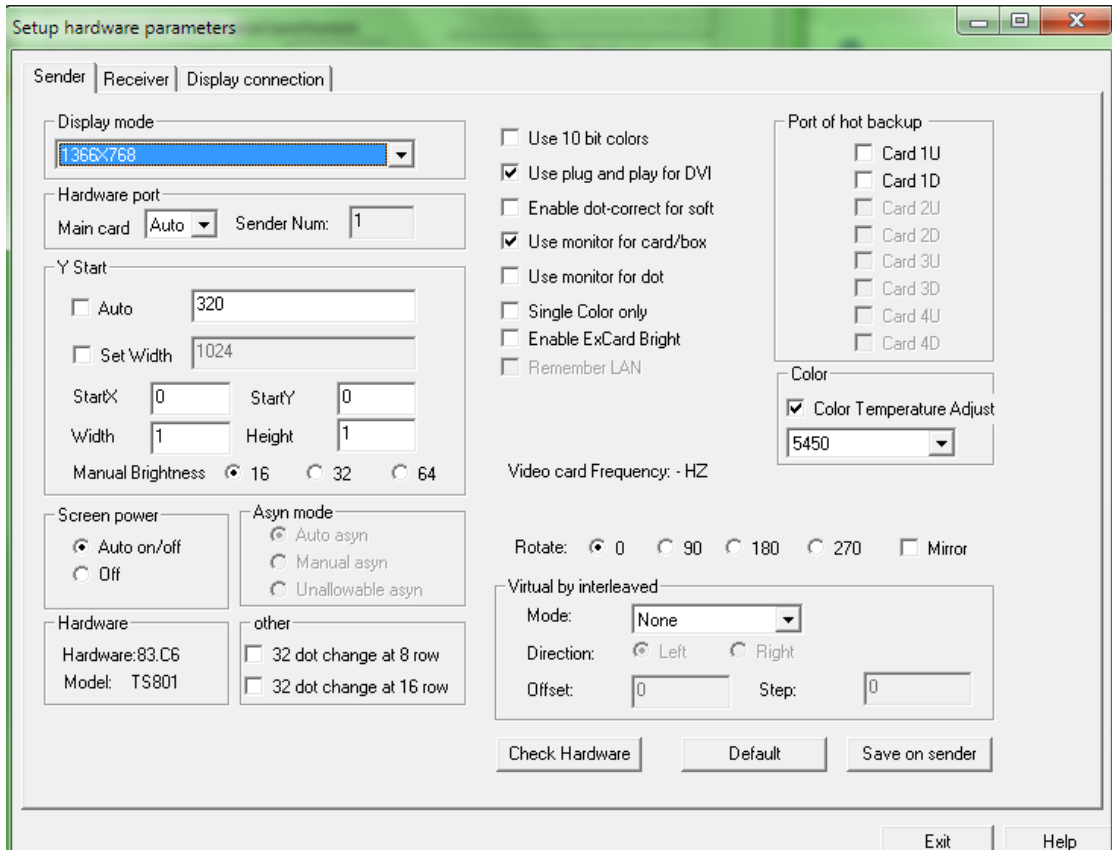

## 2. Sender setup

### Settings:

**Display mode:** choose the same resolution as computer monitor or as video processor output resolution

**Note:** LedStudio will detect the attached Sending Card Model and list the available resolutions.

**Default:** set the sending card to Default settings.

Click **Save on sender**.

### Other Details:



**Main card:** which COM port is used for LedStudio to communicate with sending card

**Sender Num:** the quantity of sending card(s) connected to computer

**Y Start**

Auto

Set Width

StartX  StartY

Width  Height

Manual Grey  16  32  64

**Y Start:** Auto or set the Y start of sending card. For example, 120, then the sending card will read data from 0,120 of computer desktop.

**Set Width:** set the pixel numbers that the sending card needs to carry, then it will enable more height for U RJ45 output.

**Start X, Start Y:** set (X, Y) for sending card to start reading data from computer desktop. Start X, Start Y is based on Y Start. For example, Y start (0, 120), StartX, Y (120, 120), then sending card start reading data from (120, 240) of computer desktop.

**Note:** in **Screen Area**, **Start X**, **Start Y** cannot be set beyond the RJ45 U port resolution; otherwise the led screen would freeze or appear wrong codec. In here, **Start X**, **Start Y** can set within the sending card resolution.

**Width Height:** it is same function as **LedStudio**, **Option Meanu**, **Screen Area**, **Zoom Display**. for example, a led display resolution is 96\*64, to show a larger part of computer desktop like 288\*192, then input width  $96/288=0.33$ , height  $64/192=0.32$ .

**Manual Grey:** change Grey instantly. 16bit (16384), 32bit (32768), 64bit (65536)

**Screen power**

Auto on/off

Off

**Asyn mode**

Auto asyn

Manual asyn

Unallowable asyn

**Screen power:** to turn on/off enable LedStudio to control on/off

**Screen power off:** turn off sending card signal for output

**Asyn mode:** Not yet available

**Hardware**

Hardware:83.C6

Momdel: TS801

**other**

32 dot change at 8 row

32 dot change at 16 row

**Hardware:** show sending card info by clicking **Check Hardware**

**Other:** leave it empty.

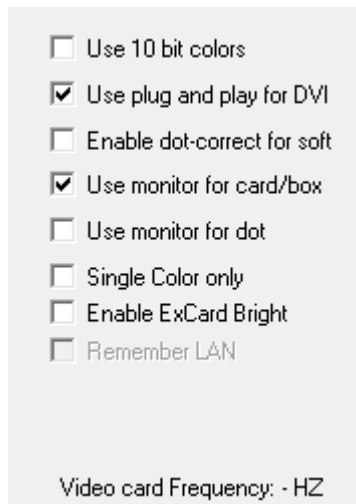

Enable functions of control system. Leave it as default.

**Use 10 bit colors:** when 10 digit signal input is applied to TTL;

**Use plug and play for DVI:** automatically enable DVI port of graphic card;

**Enable dot-correct for soft:** enable dot correction effects;

**Enable dot-correct for hardware:** reserved for future development.

**Use monitor for card/box:** when enable, go to Option menu, Led Screen Monitor, will have Card/box monitor window, to read each receiving card firmware code and temperature and so on;

**Use monitor for dot:** reserved for future development;

**Single color only:** black and white color;

**Enable ExCard Bright:** enable function board automatically brightness adjustment function;

**Remember LAN:** only for non-sending card control mode;

**Video card Frequency::** working frequency of current graphic card;

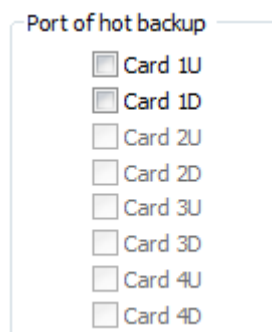

**Port of hot backup:** Select a port for backup data.

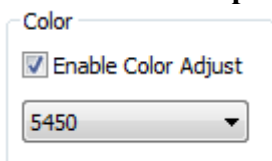

Change the color temperature on led display

**Rotate:** rotate image function realized by sending card, not by graphic card;

Virtual by interleaved

Mode:	<input type="text" value="None"/>
Direction:	<input checked="" type="radio"/> Left <input type="radio"/> Right
Offset:	<input type="text" value="0"/>
Step:	<input type="text" value="0"/>

Leave it as default.

Make G-R-B 7-formed led display show virtual.

### 3. Receiver setup

#### 3.1 Settings

1. Load **RCG** file by click **Load from files**.

**Note:** .RCG file is generated by running **intelligent setup**. It is driver for linsn control system to work with led display. (Get RCG file from the led display supplier)

2. **Send to receiver**, if image is showing correctly in led display, **Save on receiver**.

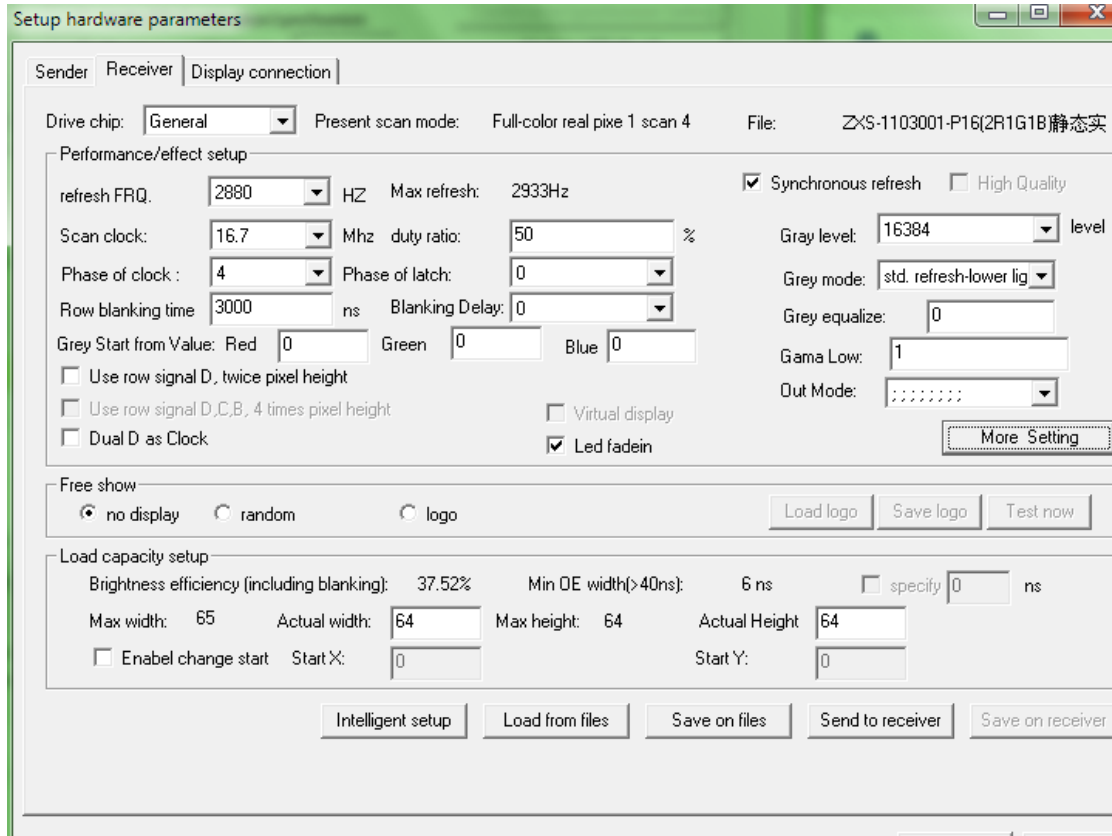

#### 3.2 Other details:

**Drive chip:** Choose the LED Driver IC used in the LED Display. General refers to supported Constant Current Driver IC.

**Present scan mode:** Load the correct .RCG file from LED Display Manufacturer or after finishing intelligent setup, software will recognize the scan mode of the LED module design.

**File:** .RCG file name. After finishing intelligent setup properly, click **Save on files** to name and save the .rcg file. For example: full-color 1/8 scan 8 rows/zone.

**Refresh FRQ:** LED Display refresh frequency, has to be **multiple of graphic card frequency**. The higher the refresh frequency is, the more stable image will be on the screen. If a camera is used to shoot image on LED Display, to avoid scan line, user should set the refresh frequency above 600HZ. Generally speaking, for double-color screen, refresh frequency set 60—75HZ; For indoor full-color display, 180—600HZ; For outdoor full-color display, 300-1200HZ.

**Max refresh:** the maximum refresh frequency supported

**Synchronous frequency:** For double-color display, it doesn't matter; for full-color display, this item has to be ticked. For *high-refresh* mode in **Grey mode**, Synchronous refresh is locked ticked.

**High bright:** high brightness. in high-refresh mode, High bright option make low-grey-level part looks better, but it will lower **Brightness Efficiency**.

**Scan clock:** the theoretic max scan clock is on the Driver IC specification.

Scan clock also depends on design and performance of LED Module Drive Board (PCB design). The higher scan clock it is, the more Max width and higher gray level is available, normally 16.7MHz.

**Duty ratio:** it is the duty ratio of scan clock, changing this will affect the scan clock, enable scan clock go higher. Duty ratio is set default 50%. (Settings for Led manufactory)

**Grey mode:** std: standard; std<hight<higher<highest<max

Lowest light<lower light<low light<light<high light<higher light< highest light

**Gray level:** normally, gray level 256 for double-color display; 4096 for indoor display; 16384 for outdoor display. The higher the gray level is, the better image quality will be.

When Grey mode, high refresh mode, gray level with refresh means make high refresh rate priority; with quality means make gray level priority; with normal means equal balance of refresh rate and gray level;

**Phase of clock:** adjust the phase of **scan clock**, enable high scan clock. Normally 3;

Phase of latch: adjust the phase of latch;

**Row Blanking time:** value set between 10-200000. It is used to fix brightness leak. Set 3000 for double-color display; 200 for full color display. (Real pixel and virtual pixel). If high value is set for Row Blanking time, and with no effects, please check the connection of receiving card and led display, especially whether OE is reversed connected (settings for Led manufactory)

**Blanking Delay:** 0-15, work on brightness leak (settings for Led manufactory)

**Gray equalize:** The default value is 1; generally, most Led screens don't need to adjust this item. The normal gray displays from darkness to brightness, as shown in below figure: (settings for Led manufactory)



Some panels are not of good quality, so the gray level doesn't display regularly; if users adjust this item, it is possible to make the gray level normal. The adjust value range: 0-15.

**Grey Start from Value:** set start value for RGB, when Test gray level, gray level starts from the start value;

**Gama low:** set gray level by gama value;

**Use row signal D, twice pixel height:** use Row Signal D as the second Clock signal, double receiving card carries capacity for height;

**Use row signal D,C,B, 4 times pixel height:** use each Row Signal D,C,B as Clock signal, quadruple receiving card carries capacity for height;

**Dual D as Clock:** receiving card outputs two different clock signals, enable the clock for further transmission, support high scan clock;

**Virtual display:** if the led display is virtual display, and it is set to work in virtual mode, tick this item.

**Led fadein:** led display lights up gradually, avoid instant high current damaging led display;

More setting: **settings for led display manufacturer**

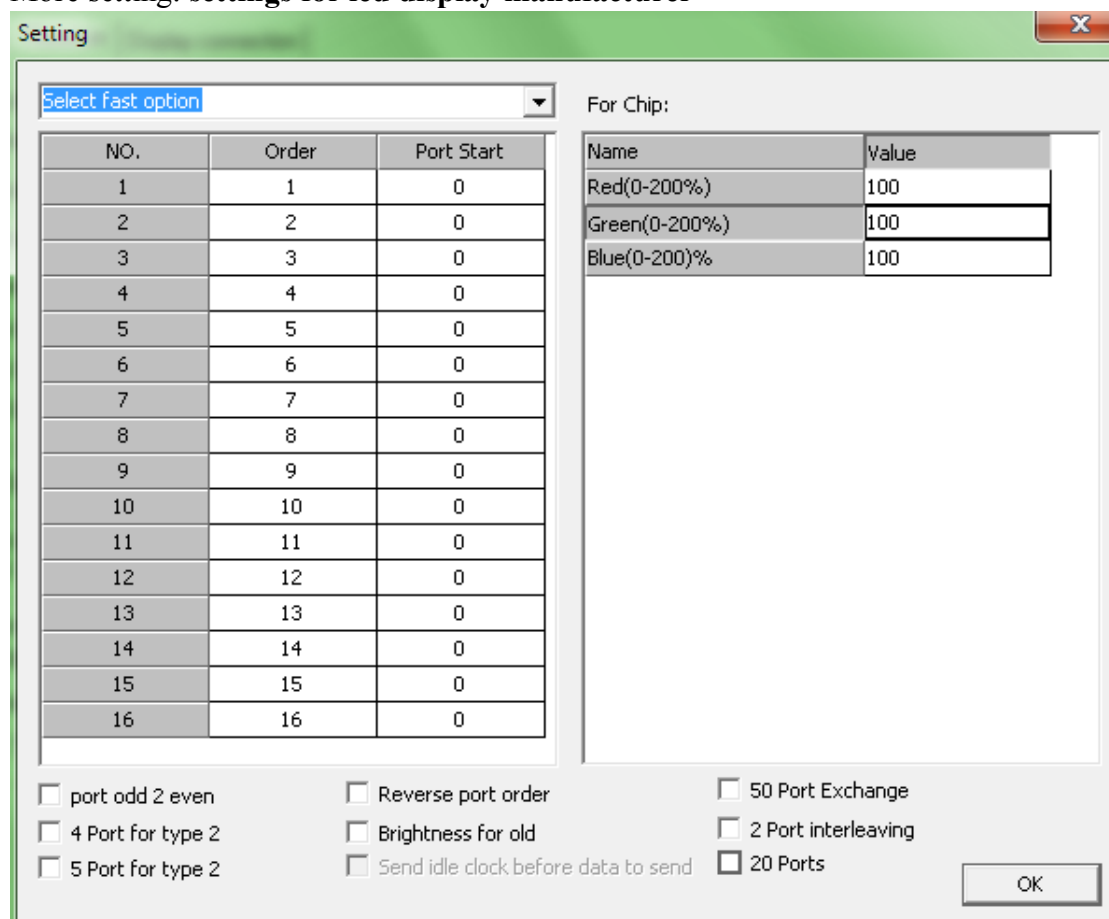

**No. 1-16:** the 16 groups of RGB signals of receiving card

**Order:** order of each group RGB signal;

**Port start:** the start X of each group RGB signal;

**For Chip:** available more settings for selected IC in **Driver Chip**;

**Port odd 2 even:** exchange **Order** of odd number and even number, which is 1-2 to 2-1, 3-4 to 4-3...

**Reverse port order:** **Order** change from 1,2,3,4,5,...,16 to 16,15,14,13,...,1.



**50 Port Exchange:** exchange the two 50-pin-port data of receiving card, which is 1-8 groups RGB data exchanges with 9-16 groups RGB data;

**4 port for type 2:** for RV802D receiving card 26-pin interface, change from original 16 groups serial data to 4 groups parallel data;

**Brightness for old:** new receiving card (RV801D with high-refresh firmware) and old receiving card (RV801D with normal refresh firmware) brightness compatible;

**2 port interleaving:** 16 groups data order change from 1-to-16 to 1, 9,2,10,3,11,4,12,5,13,6,14,7,15,8,16;

**5 port for type 2:** for RV802D receiving card 26-pin interface, change from original 16 groups serial data to 5 groups parallel data;

**Send idel clock before data to send:** applied for Driver IC needs to insert clock;

**20 ports:** add 4 more groups data to original 16 groups data, in this case, the pin definition of receiving card is changed, thus, the hub card need to change accordingly;

Free show:

**No display:** when receiving card gets no signal, led display show black;

**Random:** when receiving card gets no signal, led display show last image it plays.

**Logo:** when receiving card get no signal, led display show preset image. Image requires to be 128\*128 pixel resolution.

**Brightness efficiency:** the current brightness efficiency for led display;

**Min OE:** the minimum OE width, should be larger than 40ns.

**Specify:** manually set the OE width;

**Max width:** width pixels that one receiving card can max support. It is related with refresh frequency, gray level and scan clock, and it will change accordingly to the three items. Normally, rise up the refresh rate and the gray level will low down the max width;

**Actual width:** actual width of one receiving card need to support.

**Max height:** height pixels one receiving card can support. It is relevant to the design of led display drive board.

**Actual height:** actual height of one receiving card need to support.

**Load from files:** load .RCG file

**Save on files:** save .RCG file to computer

**Send to receiver:** After finishing the intelligent setup, or change any parameters, or upload any .RCG or .CON files, user has to click “send to receiver” to take effect on the led display.

**Note:** Can send to all receiving cards or specified receiving cards

**Save on receiver:** Click this item can save data in receiving card permanently. If not, the data lost when power is down.

### 3.3 How to run intelligent setup

There are 7 steps. (Some steps will be skipped according to different display panel.)

By running the intelligent setup, Linsn control system will fetch the info of the led display, such as scan mode, chip decode, module size, signal trend etc, then apply the suitable driver from the firmware.

#### 3.3.1 Preparation

Make sure everything is connected correctly.

1. Graphic card DVI output for sending card is set running in CLONE mode
2. Sending card(s) and receiving card(s) green indicators are blinking and red indicators on
3. Flat cable connects panel with hub card correctly
4. Before running intelligent setup, the info in below picture is needed. the info can also get from led display manufacturer.

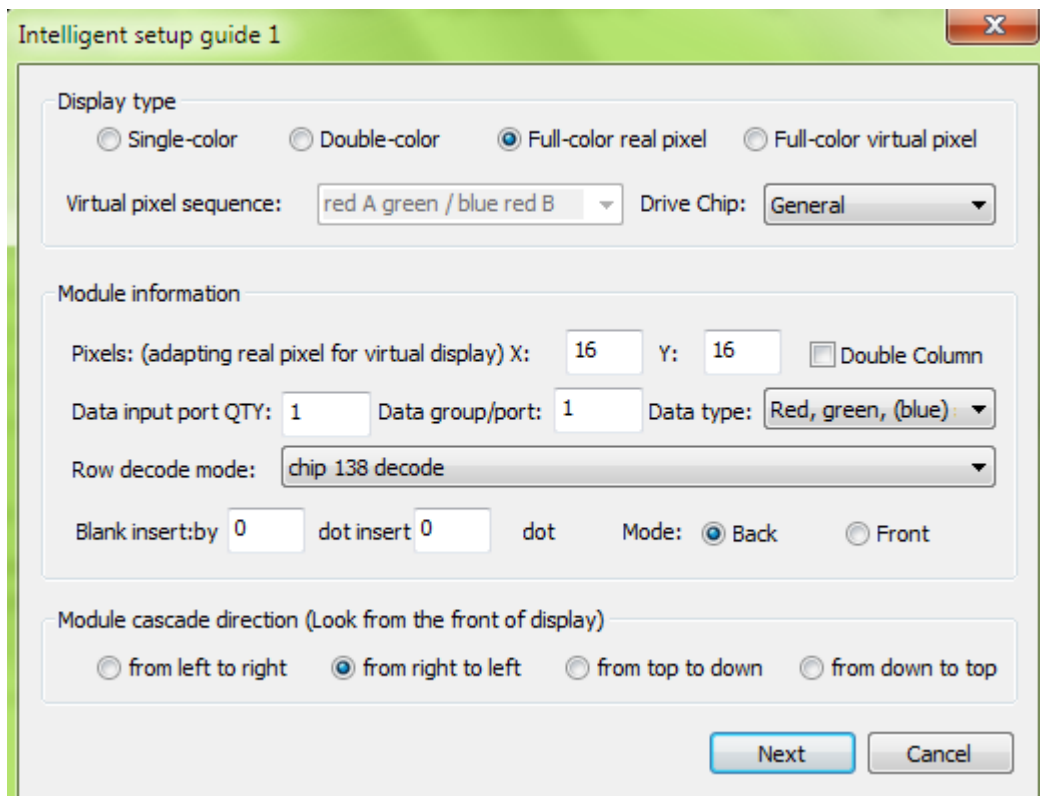

#### 3.3.2 Input LED Module Information

Click **intelligent setup**, select or input the following info, click **Next**

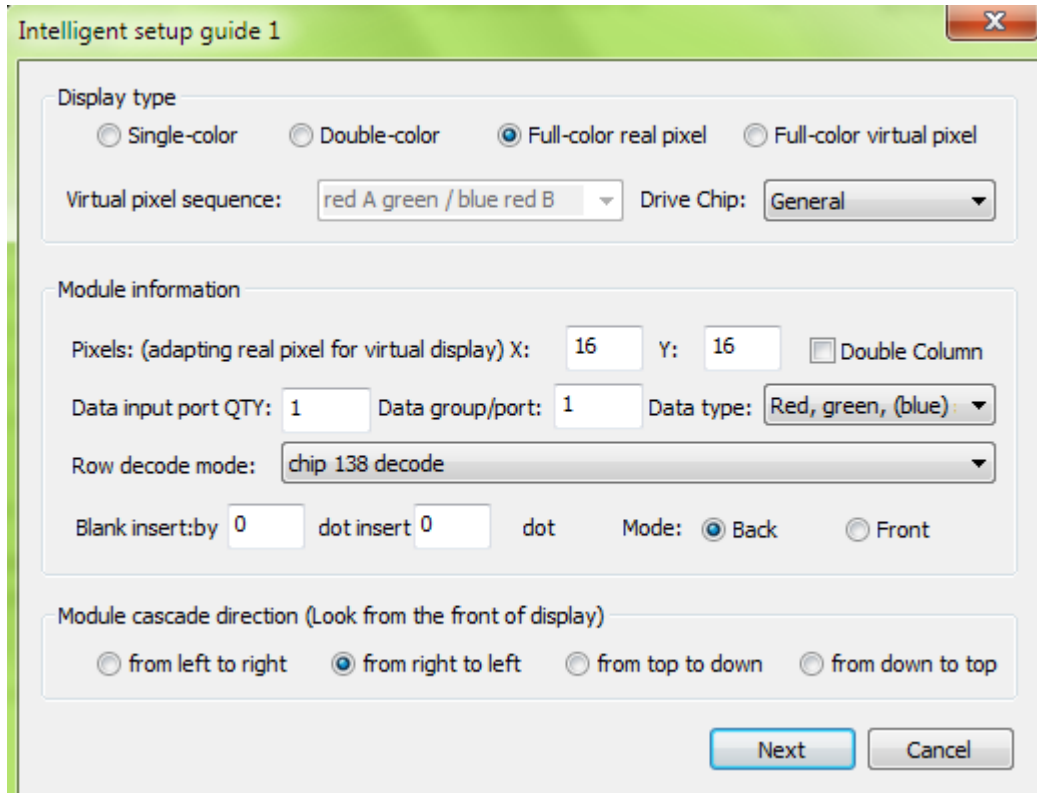

Help details:

**Drive Chip:** choose the driver chip applied to the led module;

**Display Type:** Single-color, double-color, full-color real pixel, full-color virtual pixel.)

If led display is virtual pixel, choose the right virtual pixel sequence; there are four sequences, as below:

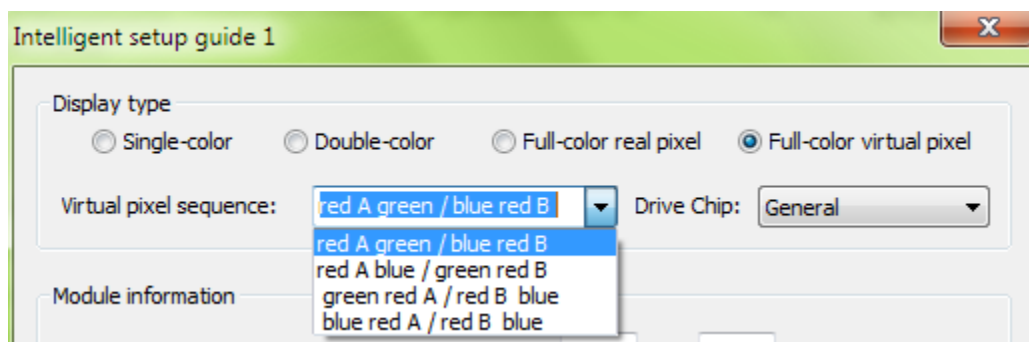

(Notice: one virtual pixel consists of two red lights, one green light and one blue light. The red in upper row is red A, and the red in lower row is red B.)

**Width (X), height (Y):** Input the resolution (pixels) of the module (also called panel/matrix,;

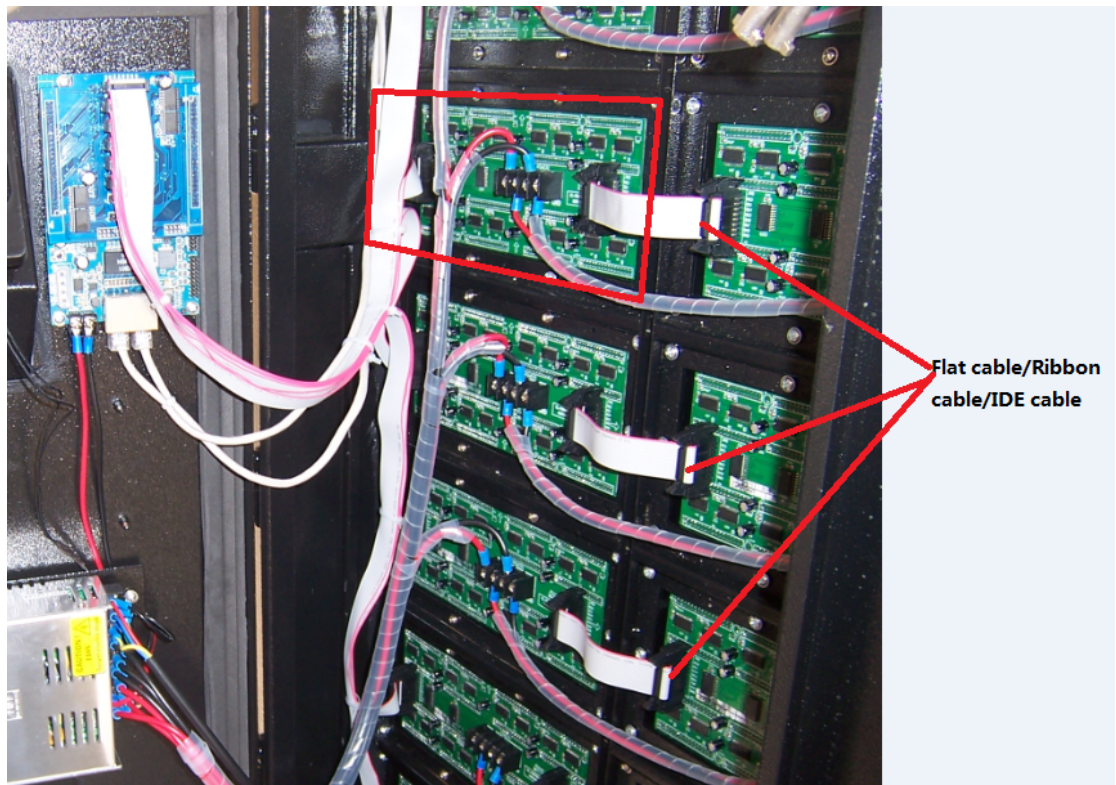
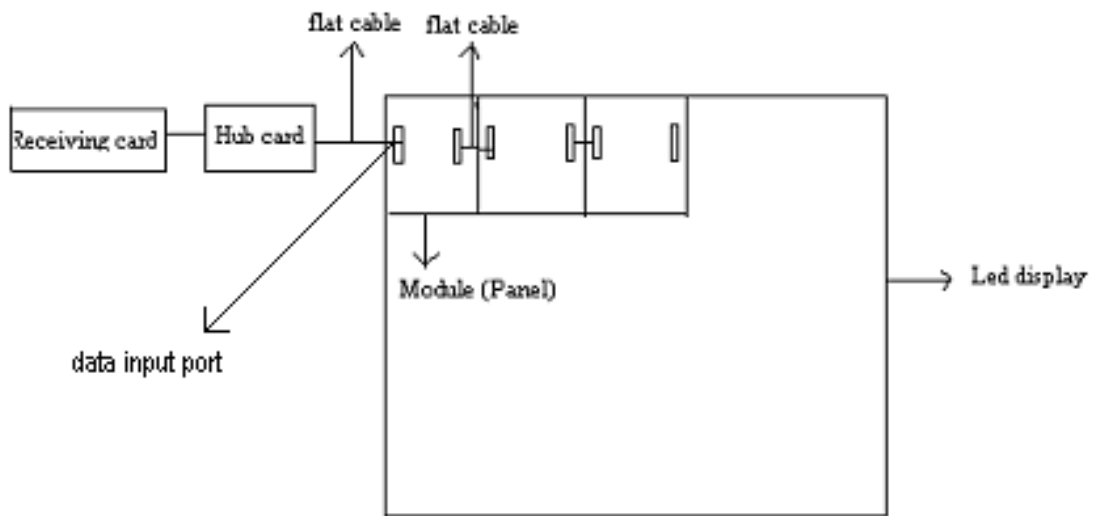

**Data input port:** Input the quantity of the **data input port**, most of the modules are one or two, as above picture it is one data input port (one input port in the left and one output port in the right).

**Data group/port:** Quantity of **data group/port** for every data input port. If hub card is Linsn Hub Card, it has pin assignment in each pin. RGB signals can be counted.

**Data type:** Generally, the first data type (Red, green, (blue) separately) for Led display, the other items for light-decoration.

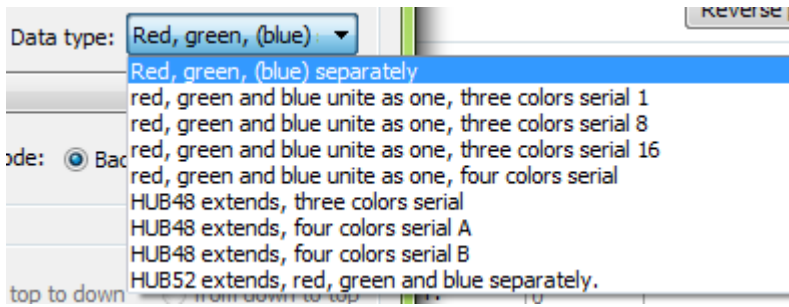

**Row decode mode:** Choose the row decode mode (Unknown or not in the following options\static, no decode\no decode chip, row drive directly, with OE\nno decode chip, row drive directly, no OE\chip 138 decode\chip 139 decode\chip 145 decode\chip154 decode\chip 164 decode\chip 192 decode\chip 193 decode\chip 595 decode\chip 4094 decode)

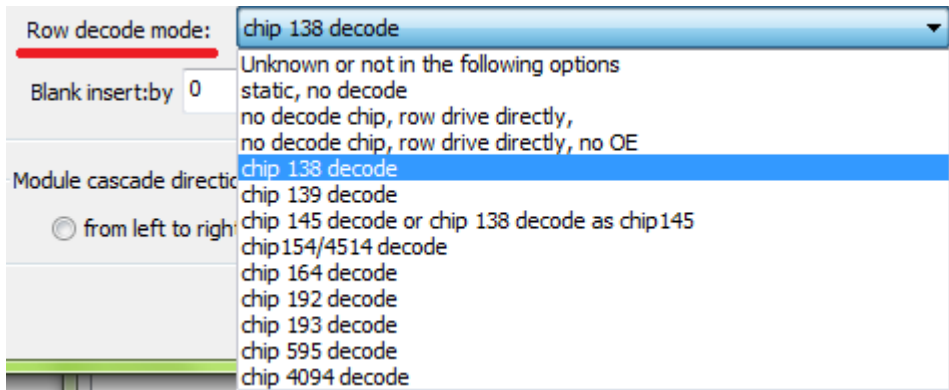

**Module cascade direction:** how signal goes. Look from the front of LED Module. Choose the right one according to modules cascaded way.

**Double column:** for special PCB design;

**Channels of chip:** channels of the driver chip

**Total chips:** for special PCB design which leaves some driver chips empty;

### 3.3.3 Watch and Select

1. Watch module changes: choose the right status according to led module reaction, for example, status 1 shows white, and status 2 shows black. Click **Next**

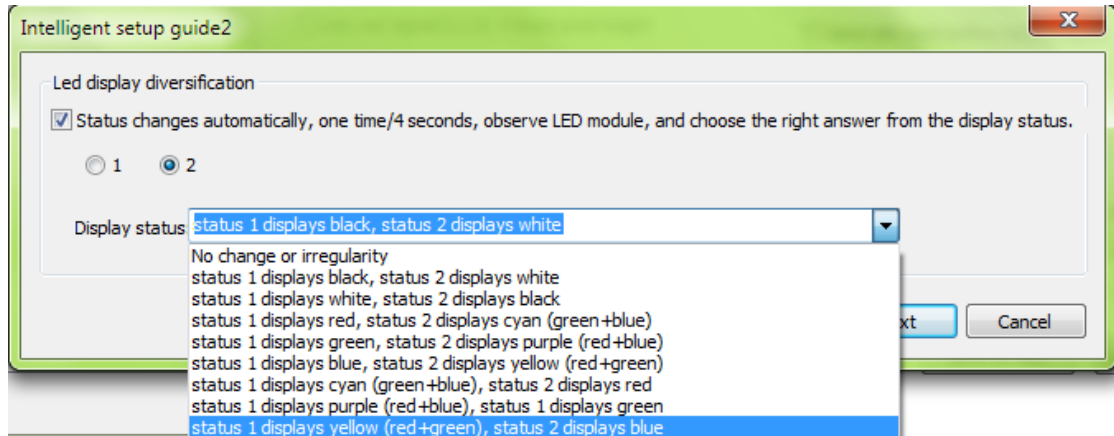

2. Watch module changes: choose the right status according to led module reaction. Click **Next**

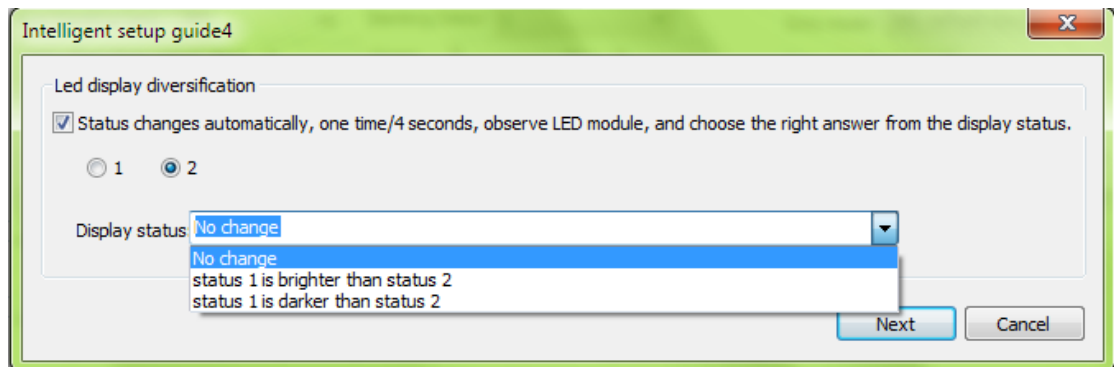

3. Watch the color that the module shows and choose accordingly, for example, status 1 displays red, and status 2 displays green. Select the right one. Click **Next**

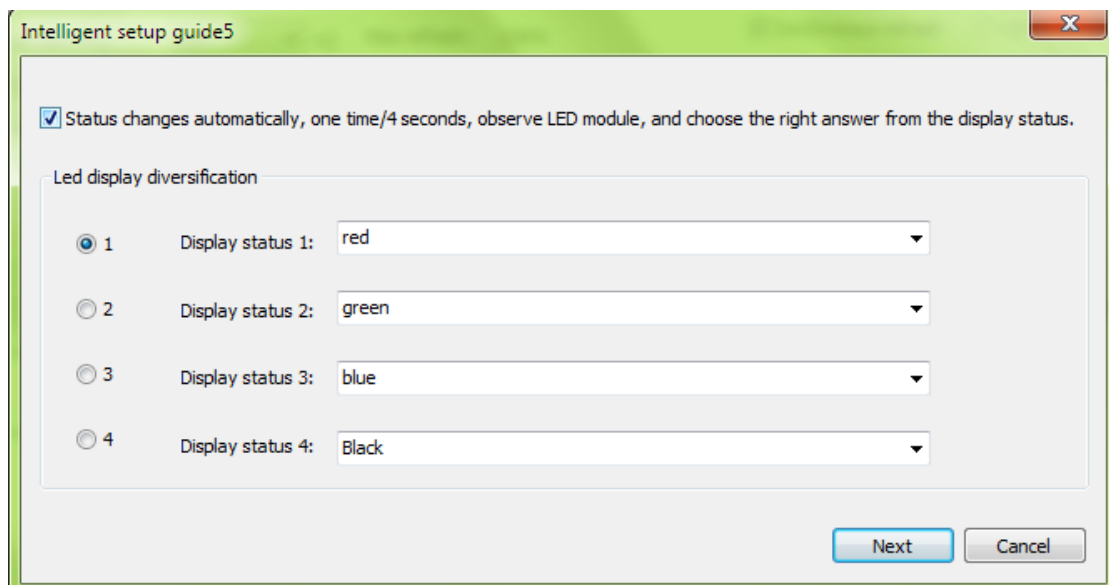

4. Watch the module: how many rows are bright totally, choose the number in **Bright rows of LED display**:

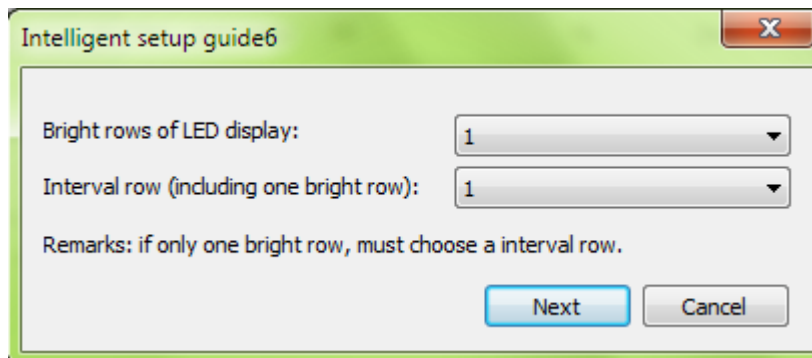

**Interval rows** mean how many black (dim) rows between two bright rows, and then add one bright row for the total interval rows. For example, as shown in below figure, there is one black/dark (mid) row between two bright rows, choose 2 ( $1+1=2$ ) rows for the interval rows, 4 rows for bright row.

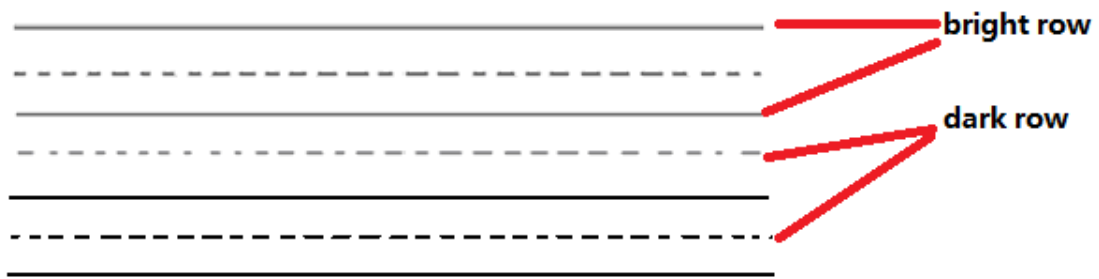

If there is no black (mid) row between the bright rows, select 1 row for the interval row, as shown in below figure: 4 rows for bright rows, and 1 for interval row.

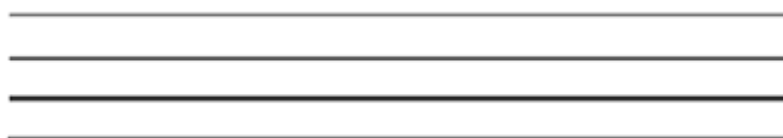

Choose the right one according to your module.

5. Watch which pixel is light up in the module  
 Then click the corresponding grid in the following window



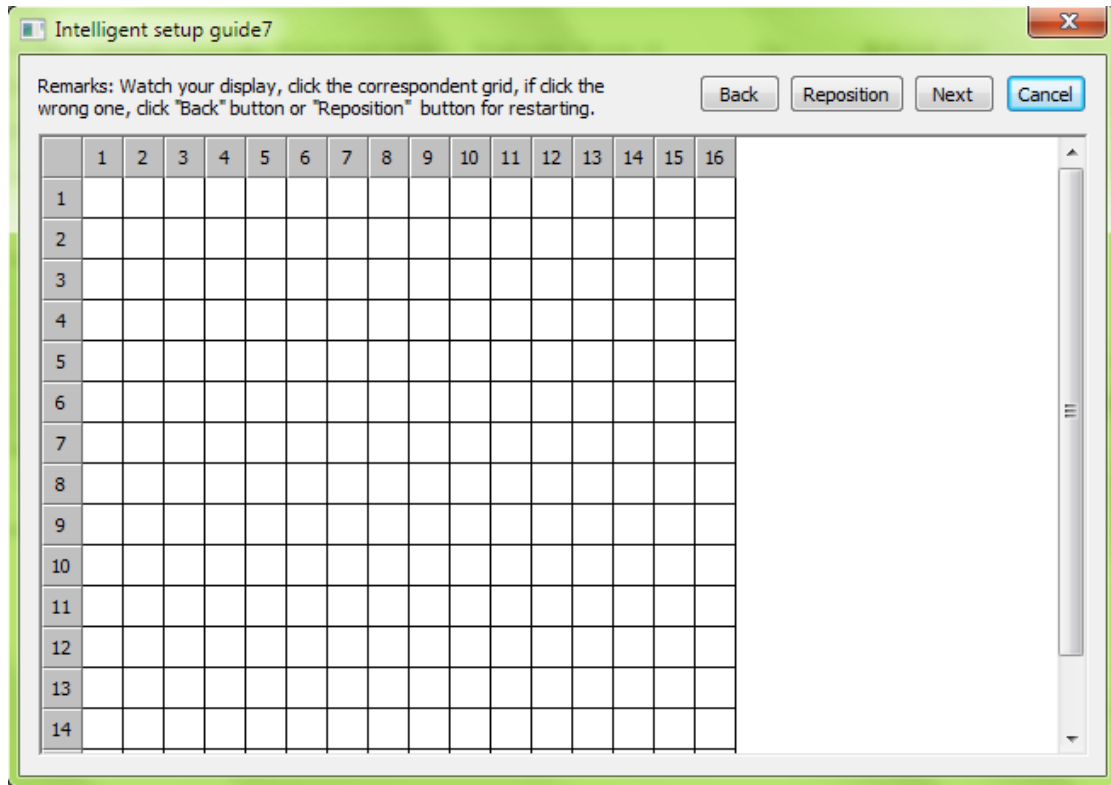

After clicking the grid, another pixel will light up in the module  
 Continue to click the corresponding grid till the following widow appears

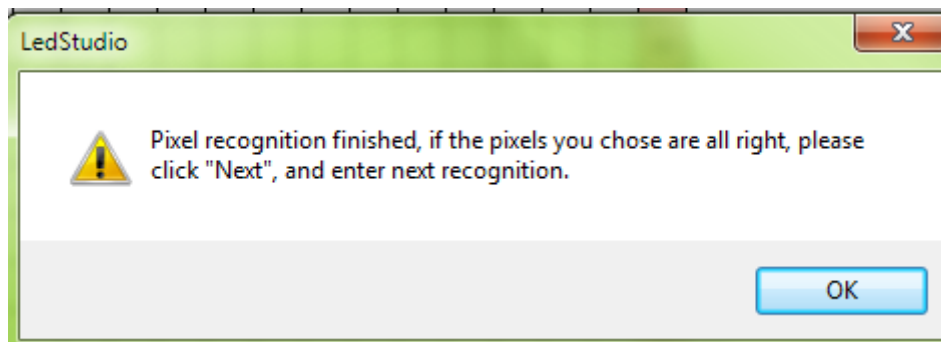

### 3.3.4 Setup Other Parameters

After finishing “intelligent setup”, send it to the receiving cards; check the image on led module or led display, if everything shows correctly, Setup the refresh frequency and gray level according to requirement of Led display.

Click **save on files** to save the **RCG** file for backup. Then click **Save to receiver** to save the .RCG in the flash memory of receiving cards.



## 4. Led Display Connection Setup

### 4.1 Settings

#### 4.1.1 Set mode: Normal

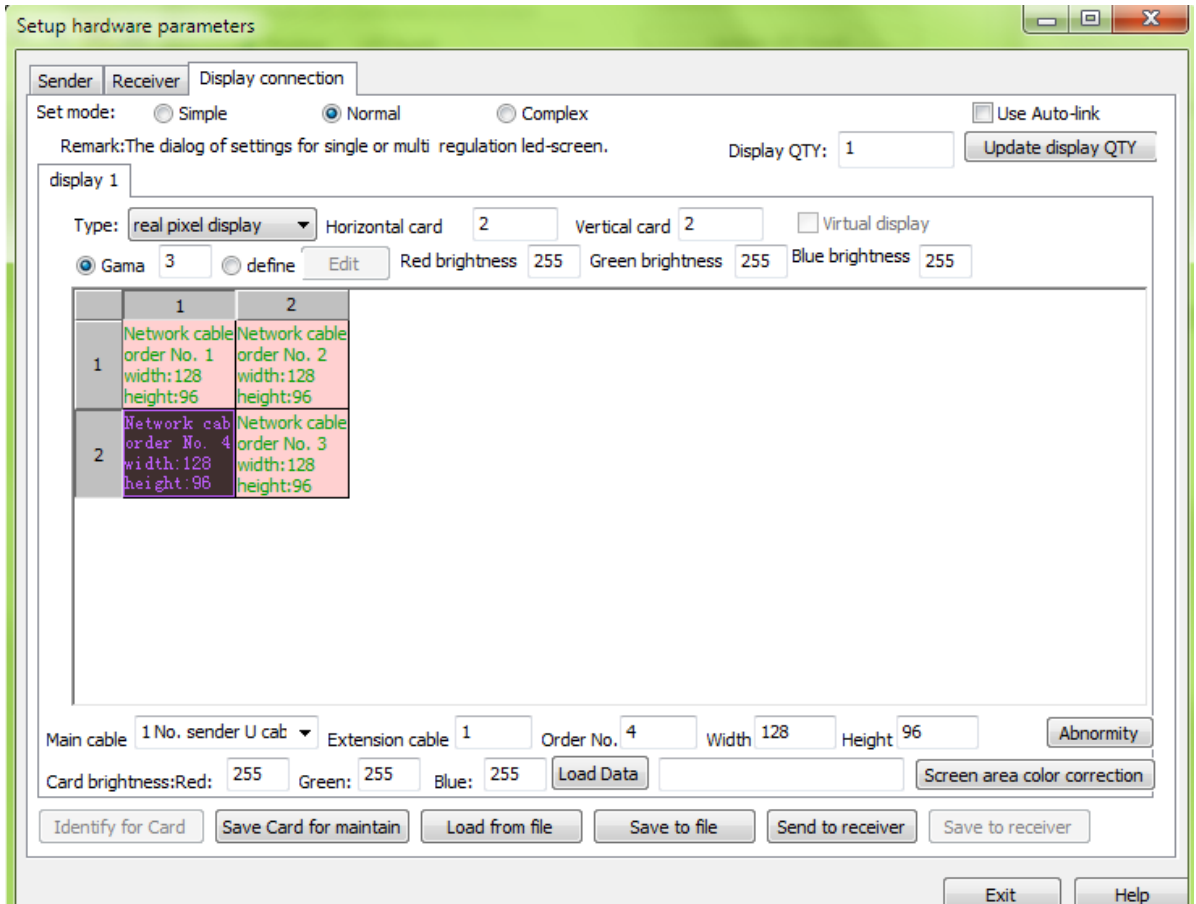

#### 4.1.2 Display QTY:

Display quantity. Input value and click Update display QTY.  
For example: 4,

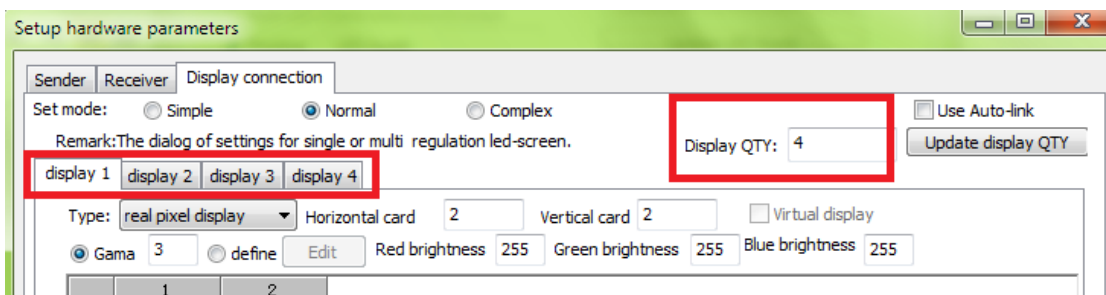

**Choose Type:** single-color display/double-color display/real pixel display/virtual pixel display

**Input receiving card numbers.**

Horizontal card: receiving card number in a row

Vertical card: receiving card number in a line

display 1

Type:  Horizontal card  Vertical card   Virtual display

Gama   define  Red brightness  Green brightness  Blue brightness

	1	2
1	Network cab. order No. 1 width:128 height:96	Network cab. order No. 2 width:128 height:96
2	Network cab. order No. 4 width:128 height:96	Network cab. order No. 3 width:128 height:96

One **pink box** stands for one **receiving card**

### 4.1.3 Input each receiving card info

Select a receiving card (a pink box)

	1	2
1	Network cab. order No. 1 width:128 height:96	Network cab. order No. 2 width:128 height:96
2	Network cable order No. 4 width:128 height:96	Network cab. order No. 3 width:128 height:96

Main cable  Extension cable  Order No.  Width  Height

**Main cable:** select sending card output port. 1U means number 1 sending card U port.

**Extension cable:** this is used when Splitter (hardware) applied.

**Order** 1 means first receiving card, order 2 means second receiving card.

Note: The first receiving card is the receiving card that first receives signals from sending card.

**Width** and **Height** means how many pixels are carried by selected receiving card.

#### 4.1.4 Input each receiving card info

Click “Send to receiver” if image is correct on led display, click save to receiver  
 Click **save to file** to save.CON in computer.

#### 4.2 Examples:

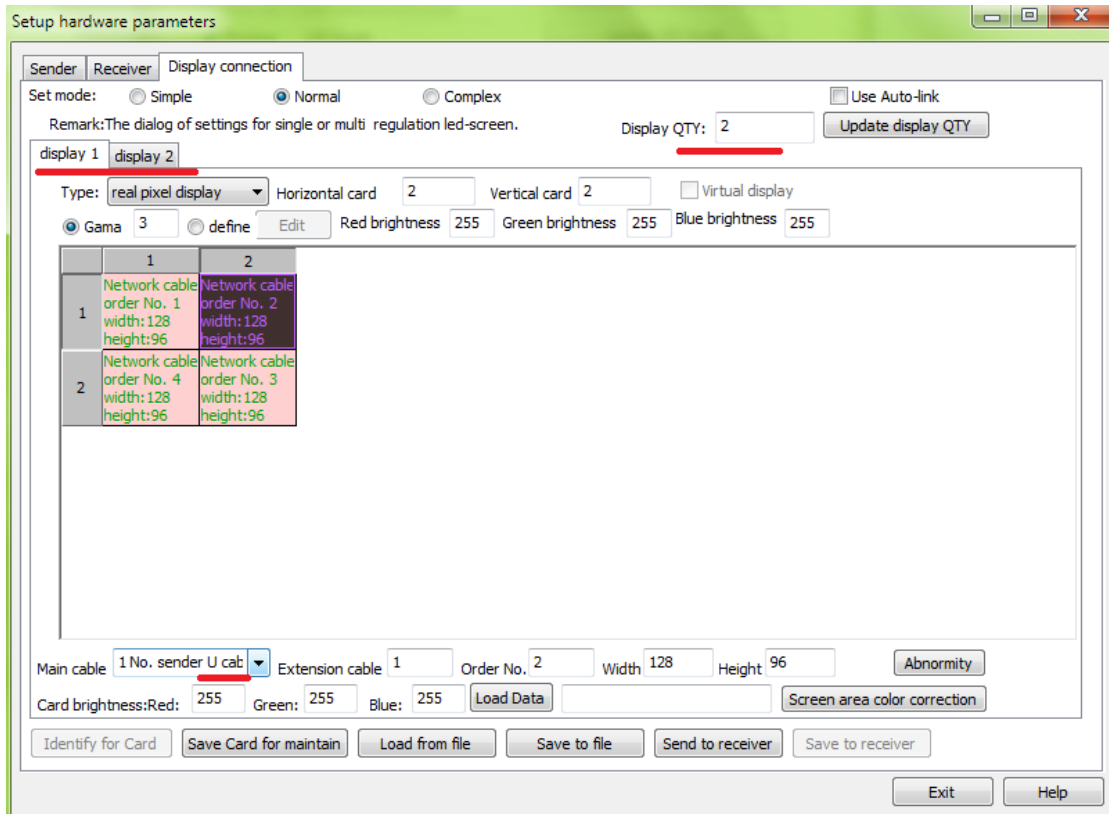

The above window means: one sending card supports two displays.

#### Display 1 info:

Real pixel display

Have four receiving cards

Gets signals from U port of sending card

When looking at the front side of the display, the first receiving card is placed at the left top cabinet, carrying 128 pixels width, 96 pixels height.

#### Display 2 info:

Virtual pixel and showing signs in virtual mode

Gets signals from D port of sending card

Have two receiving cards. One receiving card supports 48 pixels width, 48 pixels height

The other receiving card supports 128 pixel width and 128 pixels height.

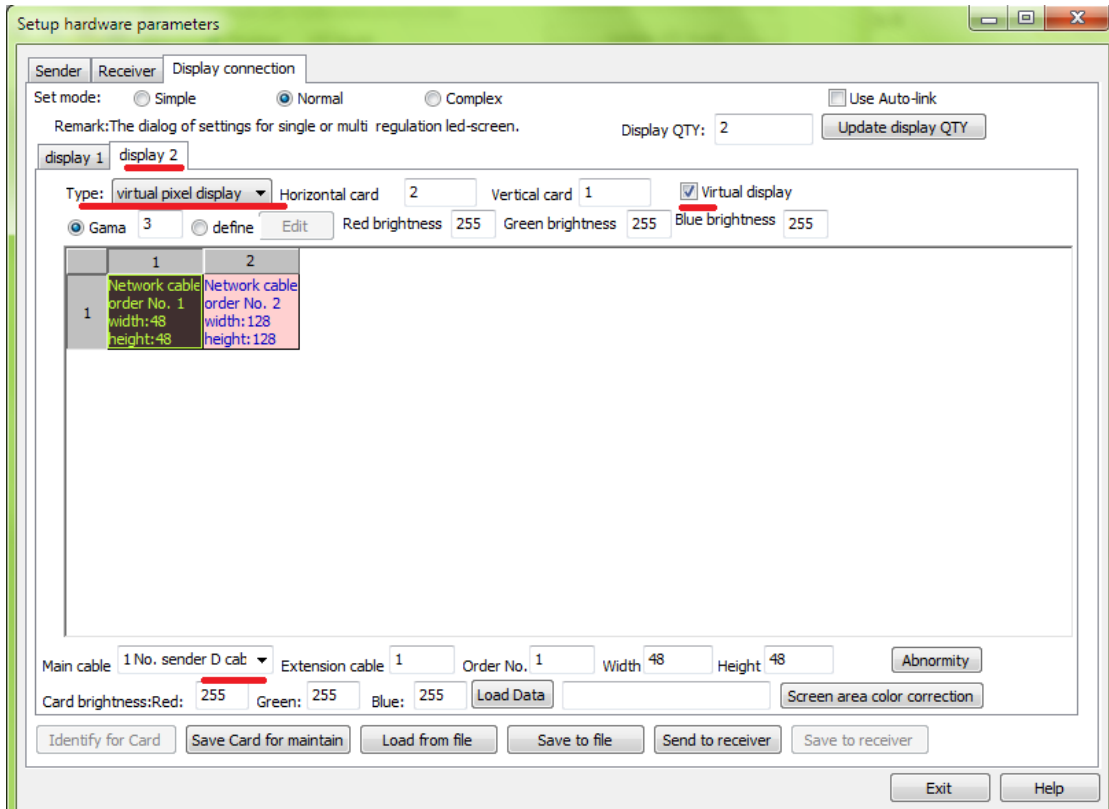

## Chapter4 Brightness Correction

### Camera Brightness Correction & Manual Brightness Correction

#### 4.1 Camera Brightness Correction

##### 4.1.1 General

#### 1. Scope:

Correction can be applied to single color, double color and full color **REAL** pixel display.

#### 2. Hardware requirements:

- Camera: Canon 5D Mark II, Canon 50D, Canon 500D, Canon7D
- Lens (50-500mm for outdoor, 70-200mm for indoor)
- 1/64 Neutral Density Filter (not a must)
- Ptz (like Manfrotto 410)
- Tripod (like Manfrotto 055DB)
- Linsn 8<sup>th</sup> generation control system

#### 2. Software requirement:

LedStudio 11.25 and above.

**Important: Virtual display is not supported.**

### 4.1.2 Preparations

1. Open LedStudio, “Option”-“software setup”-key in “linsn”-password “168” show as following:

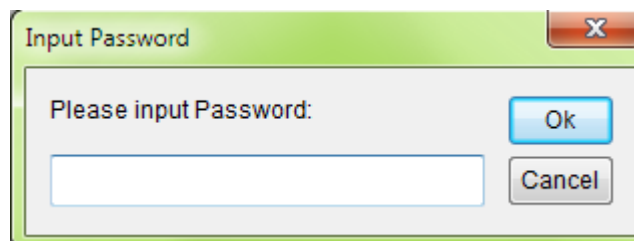
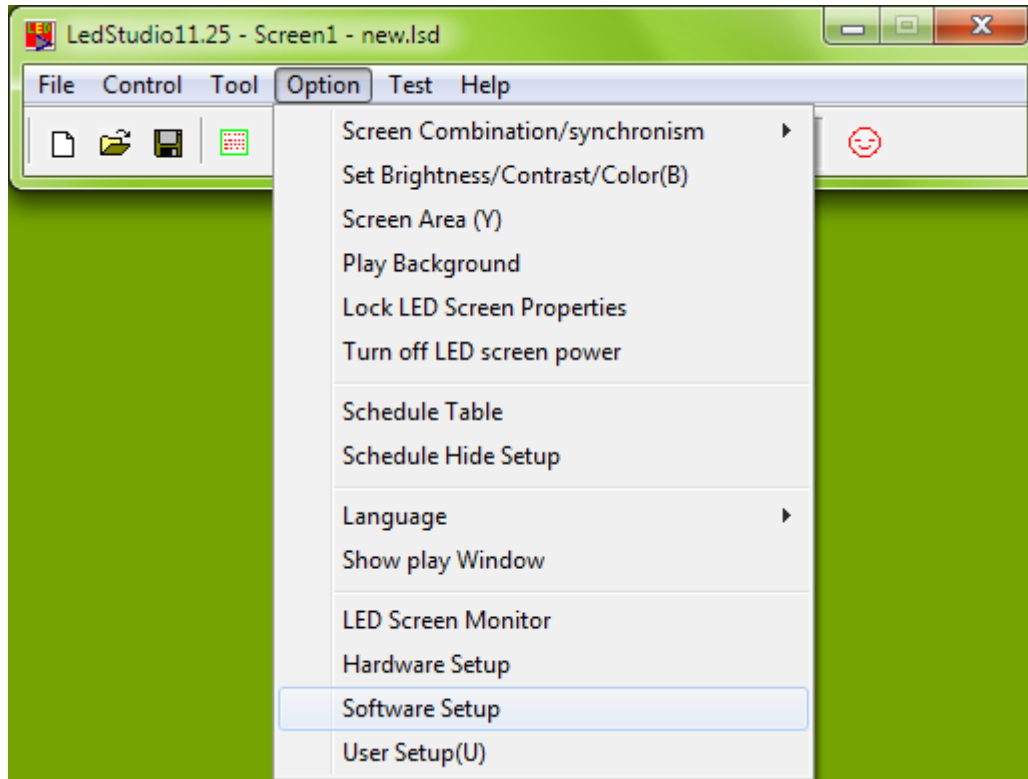

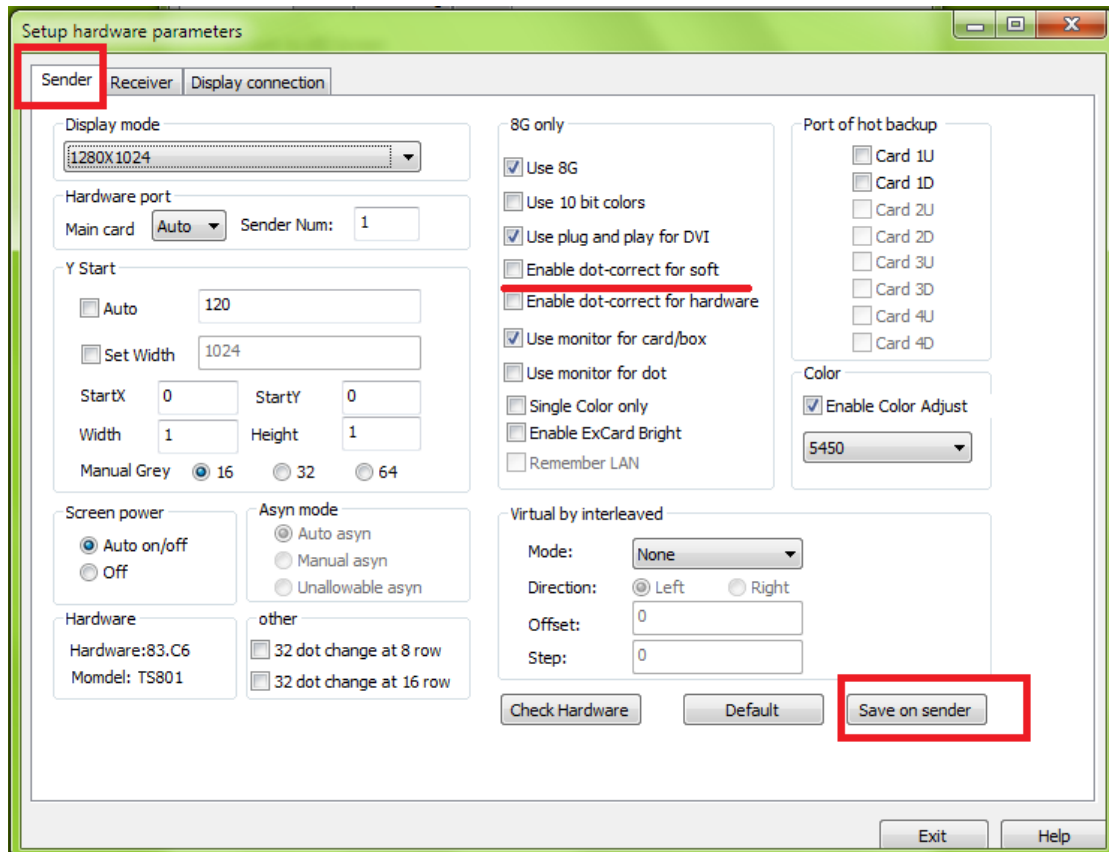

Tick **Enable dot-correct for soft** in **Sender** tag, **Save on sender**

2. Upload the **CORRECT \*.RCG** file and set the width and height, then send and save on receiver

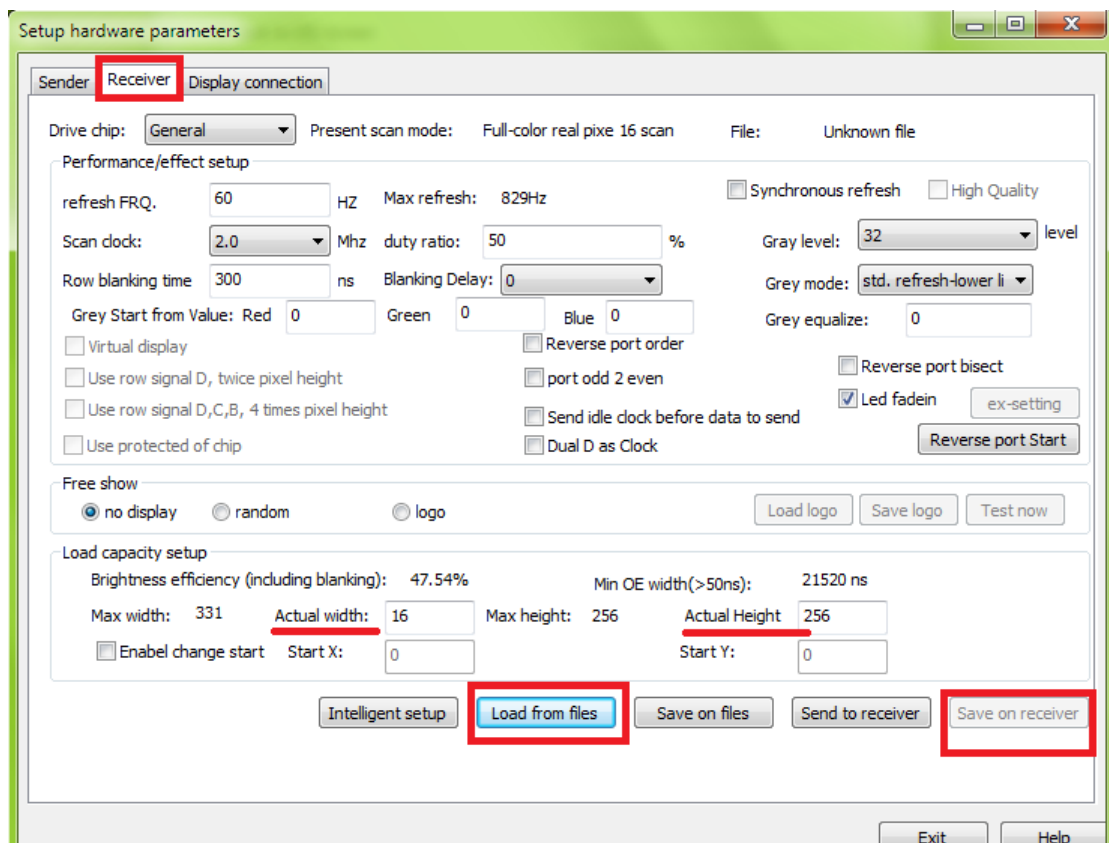

3. Upload the **CORRECT \*.CON** file from **Display connection** tag, by **Load from file**  
 Or Configure the CON file in DISPLAY CONNECTION, send and save the CON file.

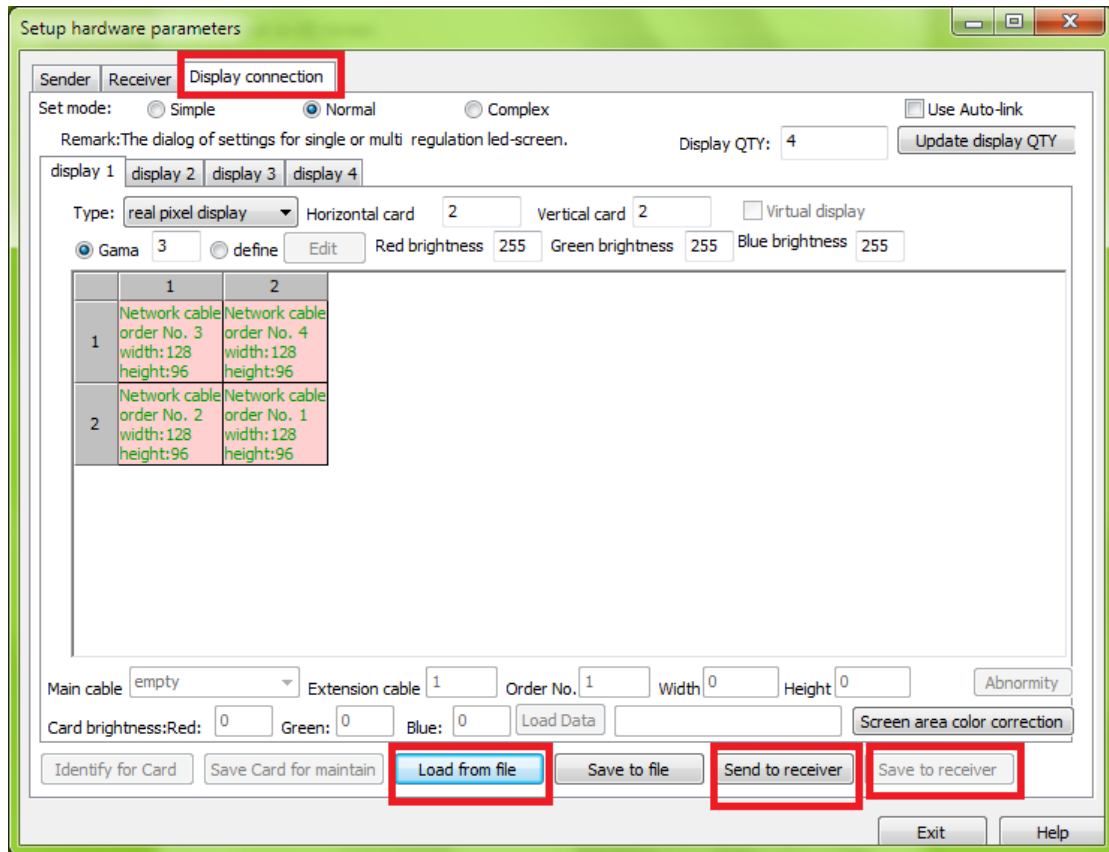

If it is only one cabinet at a time for correction, configure the width and height to be the size of the cabinet. For example: a **cabinet** with 128\*80 resolution, and with **one receiving card**, the configuration will be as this:



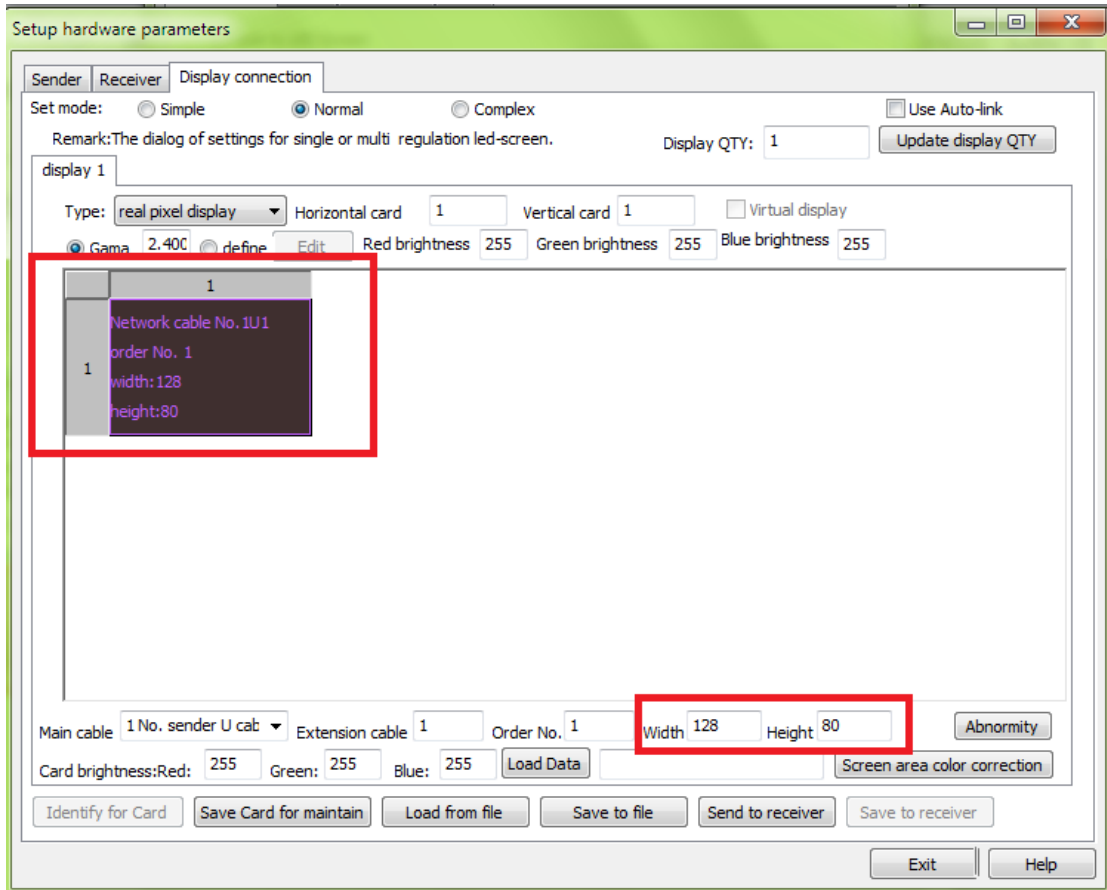

A cabinet with 128\*80 resolution and with two receiving card to support width, the configuration will be as this:

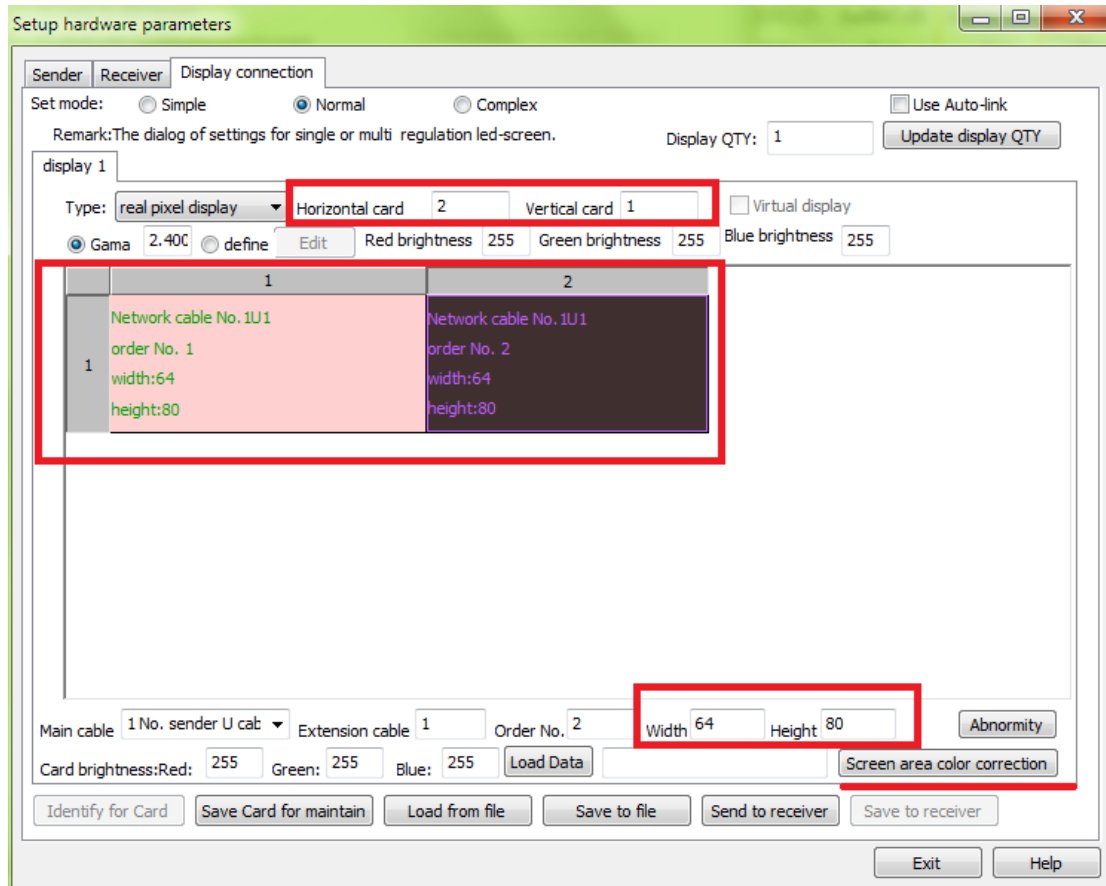

### 4.1.3 Steps of Brightness Correction

#### 4.1.3.1 Click Screen area color correction, select Photo partition

Choose a correction mode from Software Single pixel, software2x2, software4x4, software8x8  
 Extsoftware

Input info in photo partition X Y

Click **From camera**

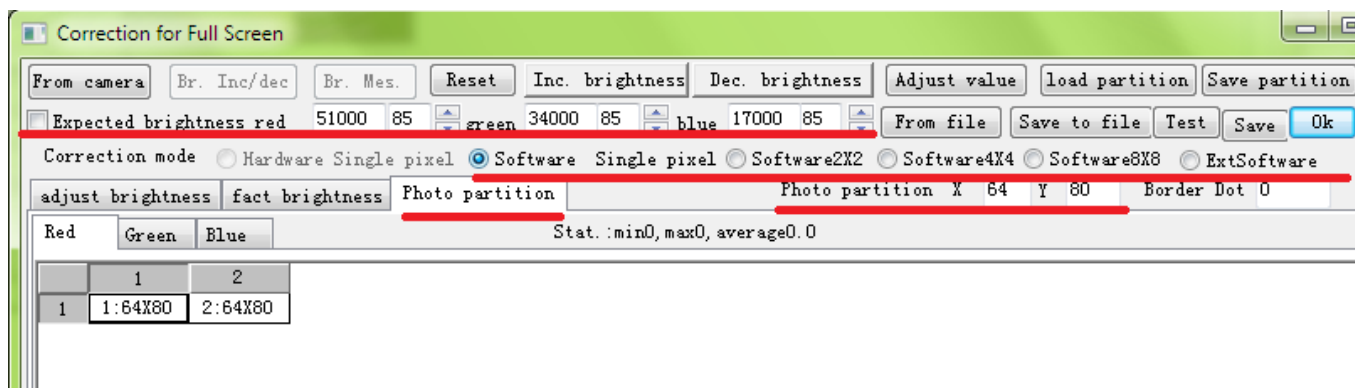

#### Other Details:

**Note:** hardware correction is to adjust the current of led display driver ic  
 Leave **Expected brightness** as default value

**Single pixel:** pixel by pixel correction, choose this if one receiving card carries within 96\*64

**Software2X2:** take two neighboring pixels in width and 2 neighboring pixels in height as one correction unit

**ExtSoftware:** enhanced software brightness correction, one receiving card supports **320\*256** single pixel correction

Note: ExtsSoftware need firmware support. And different should select **Exsoftware** or (Single pixel/software2X2/software4X4/software8X8) accordingly

**Photo partition:** set correction resolution for camera. This can be the resolution of the whole display. But a reasonable resolution according to camera lens generates a better correction effect. Our experienced technician favorite is within160\*128.

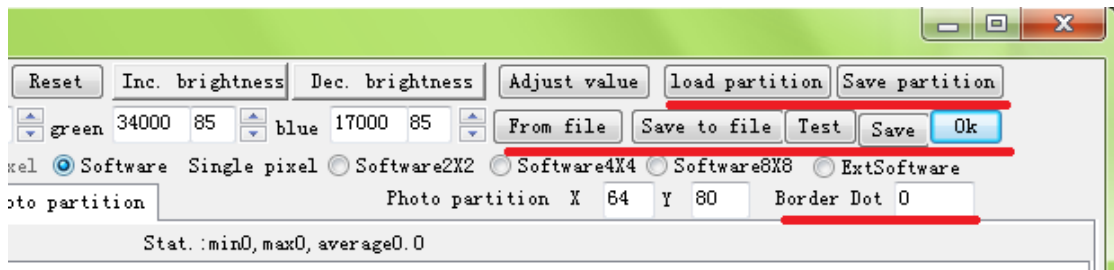

Load partition: usually for **full** (led display) correction mode; load saved correction info to whole led display.

Note: before loading the .RVS, in photo partition X, Y, input the same X and Y info with the saved .RVS file (correction info file) otherwise, the .RVS cannot be loaded successfully.

Save partition: usually for **full** (led display) correction mode; after finishing brightness correction, save correction info to file.

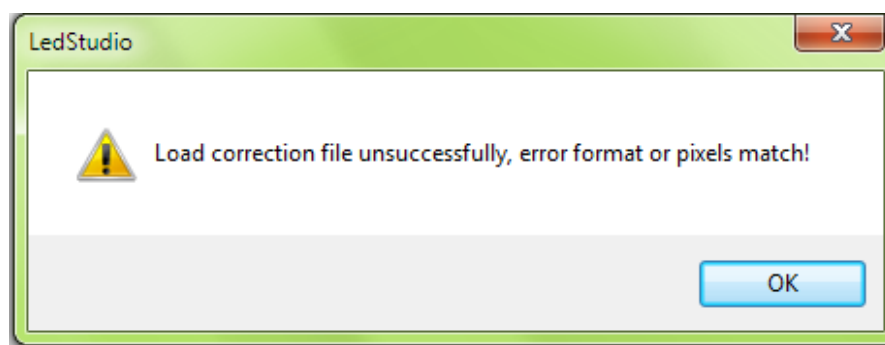

From file: usually for **box** correction mode, if receiving card is changed with new one, load saved .RVS (correction info) to new receiving card

Save to file: usually for **box** correction mode, after finishing brightness correction, save .RVS correction info to file. For example, cabinet1.RVS

Test: compare the effects with and without correction info

Save: save the .RVS file (correction info) in the flash memory of receiving card

Border Dot: leave as default value after finishing brightness correction, save correction info to file.

#### 4.1.3.2 Click from camera, Select Cr. Mode and Ms. Mode, click Preview

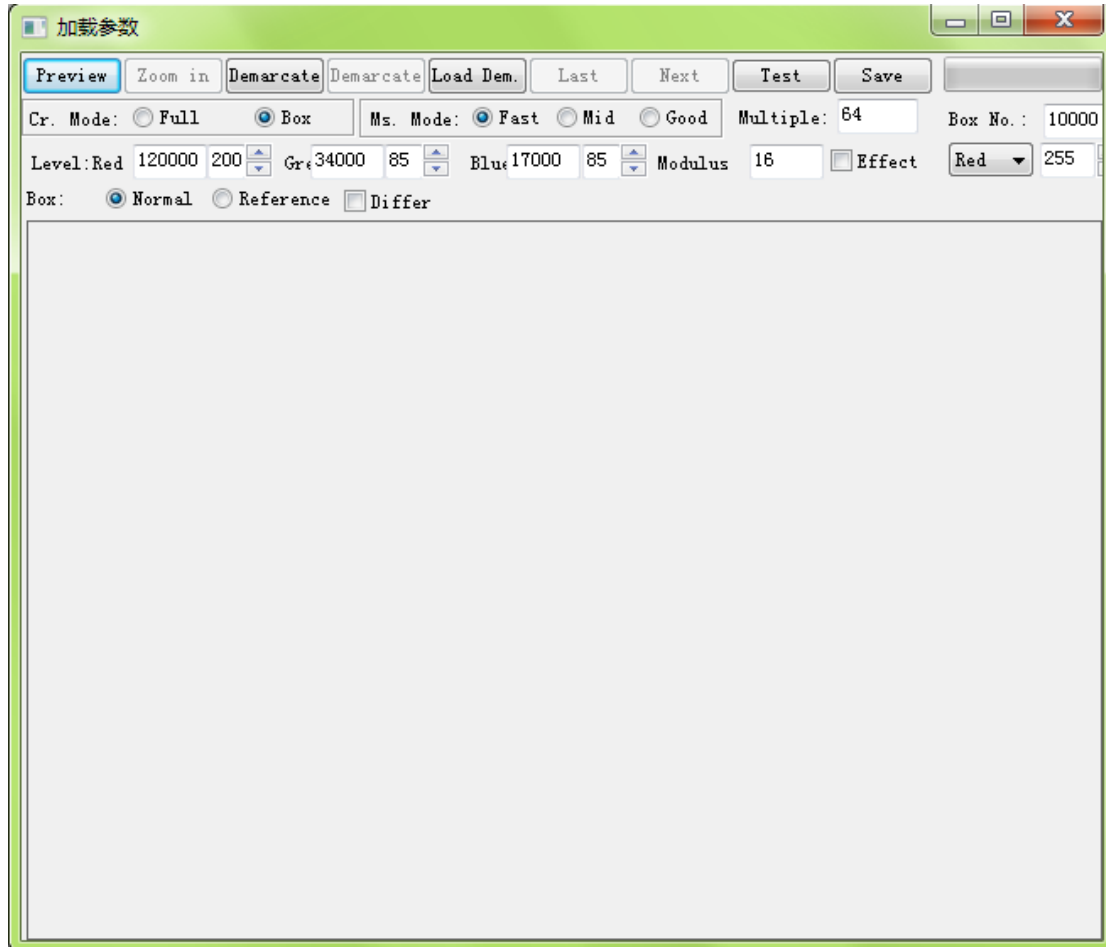

#### Other Details:



Cr. Mode: correction mode, Full means to run brightness correction for a LED Display; box for single cabinet at a time.

Ms. Mode: measure mode. Fast is most time effective, then Mid, then Good. And theoretically, good has better correction effect than Mid, then Fast.

Multiple: 64. **1/64** Neutral Density Filter

Box No.: name the cabinets

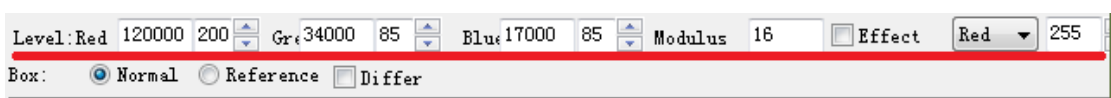

Level: leave as default value

Modulus: leave as default value

Effect: after brightness correction finished, compare the cabinets with/without correction effect

Red: choose a color for compare

255: choose a value to compare

#### 4.1.3.3 Click Preview

Adjust the camera capture window to fit the size of cabinet. In proceeding brightness correction, the distance between camera and cabinet is around 15 meters. Make sure the camera and the cabinet is 90 degree angle, otherwise the correction effect will be affected. The **red line** (shown as following picture) should just fit the **white frame** of software.



#### 4.1.3.4 Start Demarcate,

Camera will measure and take photos automatically. Click **Save Demarcate**, save the file. Click **Load Demarcate file** for the next same specification cabinet. Save time when a lot of same specification cabinets need correction.

After **Demarcate** finished, the **Demarcate** button will automatically change to **Measure** button, click **start Measure**, the camera will take pictures of cabinet showing color of Red, Green, Blue.

Click **TEST** when **Measure** finished. After **TEST** finished, the effects of before correction and after correction will be shown. Click **SAVE** to save the after correction data into receiving card, meanwhile, **.RVS** file generated in root folder of ledstudio, named "SETDATA", the **.RVS** file should marked with the according receiving card. If receiving card changed, just upload the according **.RVS** file to the new receiving card.

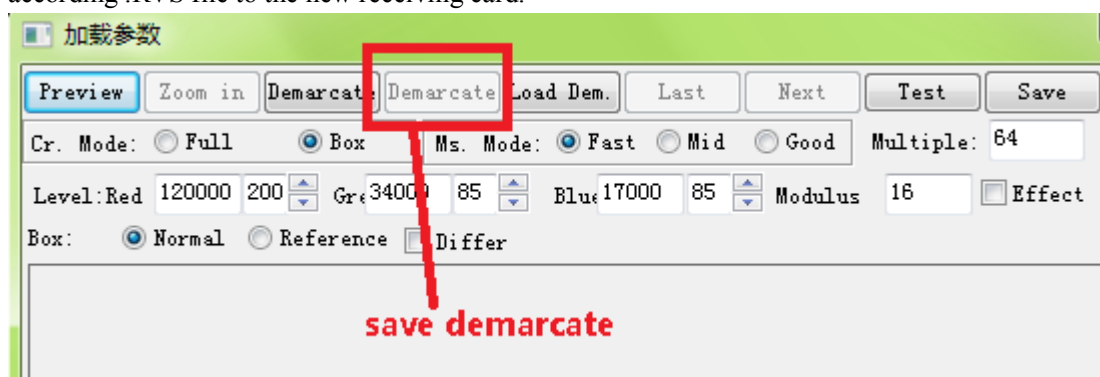

When first cabinet finish correct, **save demarcate** for the next cabinet. Next cabinet can just **load demarcate**, save time for demarcate again.

**Save** will save the correction info to cabinet receiving card.

#### 4.1.3.5 Whole LED Display Brightness Correction.

Follow the same steps, just in **photo partition**, set the width X and height Y to be the actual pixel of the cabinet, or set under X: 160, Y: 128, for example: 128\*96, 96\*64.

**NOTE:** If larger than 160\*128, the effect of brightness correction might be compromised.

When first partition is finished correction, click **Next**, till all photo partitions are finished.

**NOTE: save to file of RVS after each partition finished correction, in case of computer freeze or software crash unexpectedly. Name the RVS file clearly that helps to know how many partition correction info is contained inside.**

The correction will continue one partition after another partition, the last partition correction data (RVS) will contain all info for the whole display receiving cards.

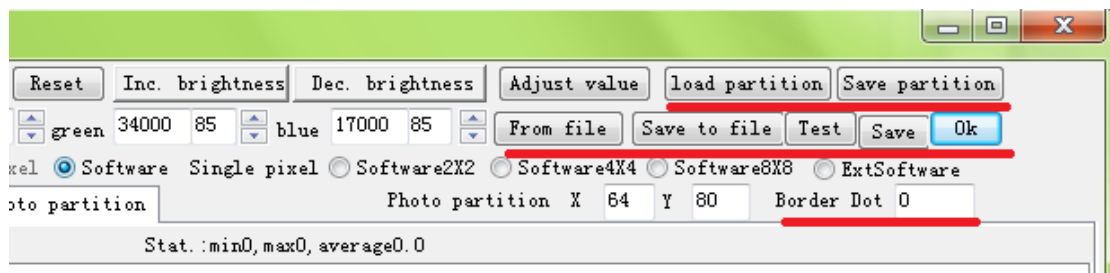

**From file**, load the RVS that contains all correction info and **save** will save the info to all receiving cards.

Back to **Sender**, enable **dot-correct for soft**, **save on sender**. Correction done!

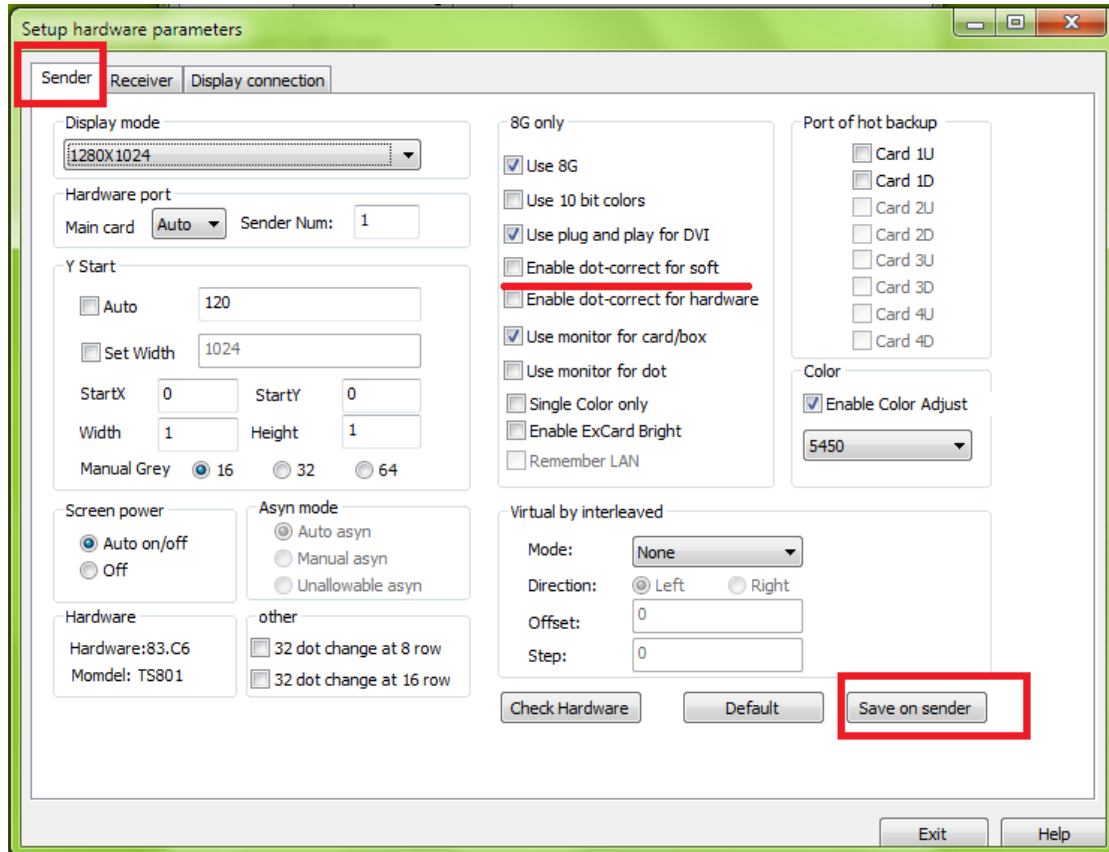

#### 4.1.3.6 Fact brightness

When brightness correction finished, fact brightness will have values of each pixel.

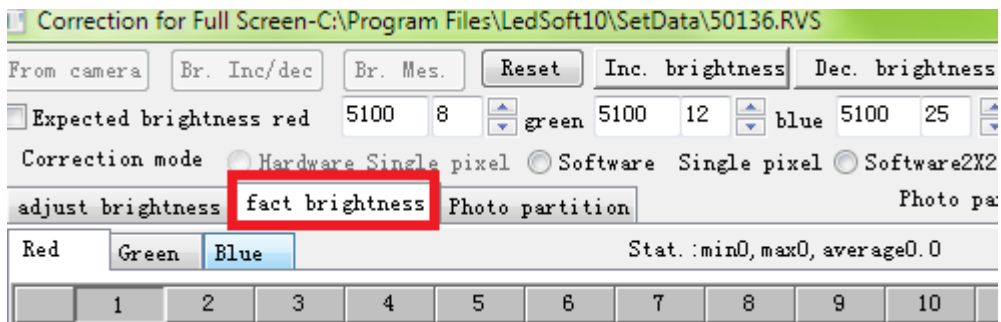

## 4.2 Manual Brightness Adjustment

LED Display with Linsn 8<sup>th</sup> control system is needed.

1. Open LedStudio, “Option”-“software setup”-key in “linsn”-password “168” show as following:

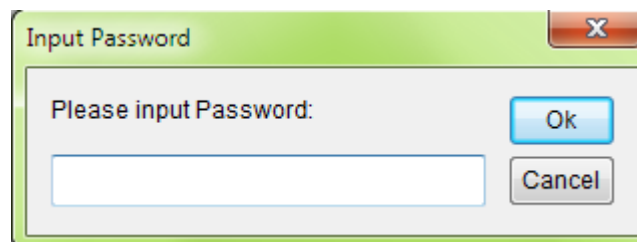
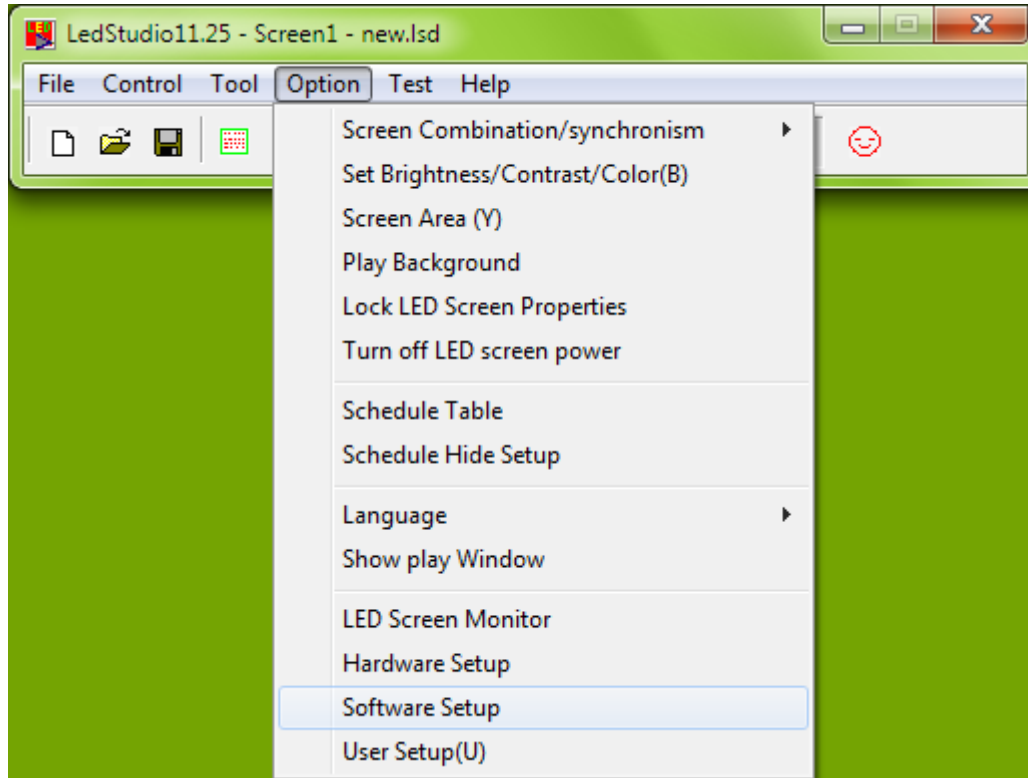



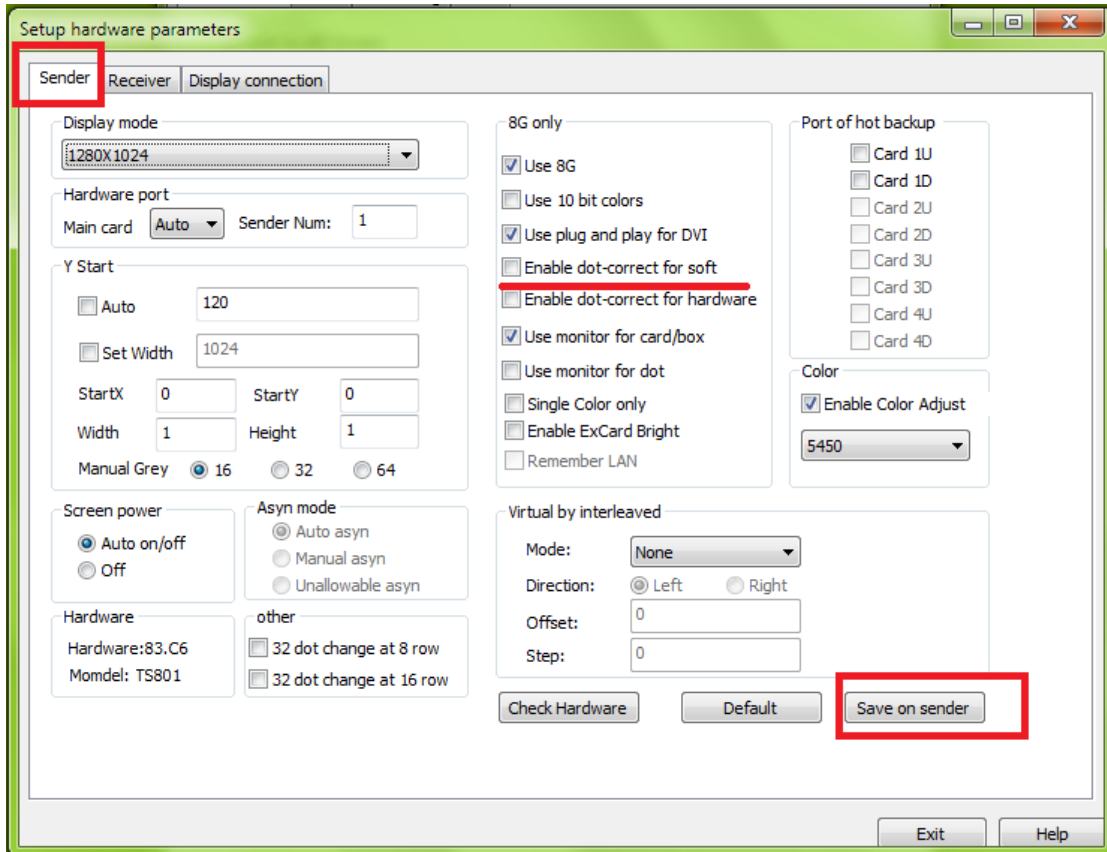

Tick **Enable dot-correct for soft** in **Sender** tag, **Save on sender**

2. Upload the **CORRECT \*.RCG** file and set the width and height, then send and save on receiver

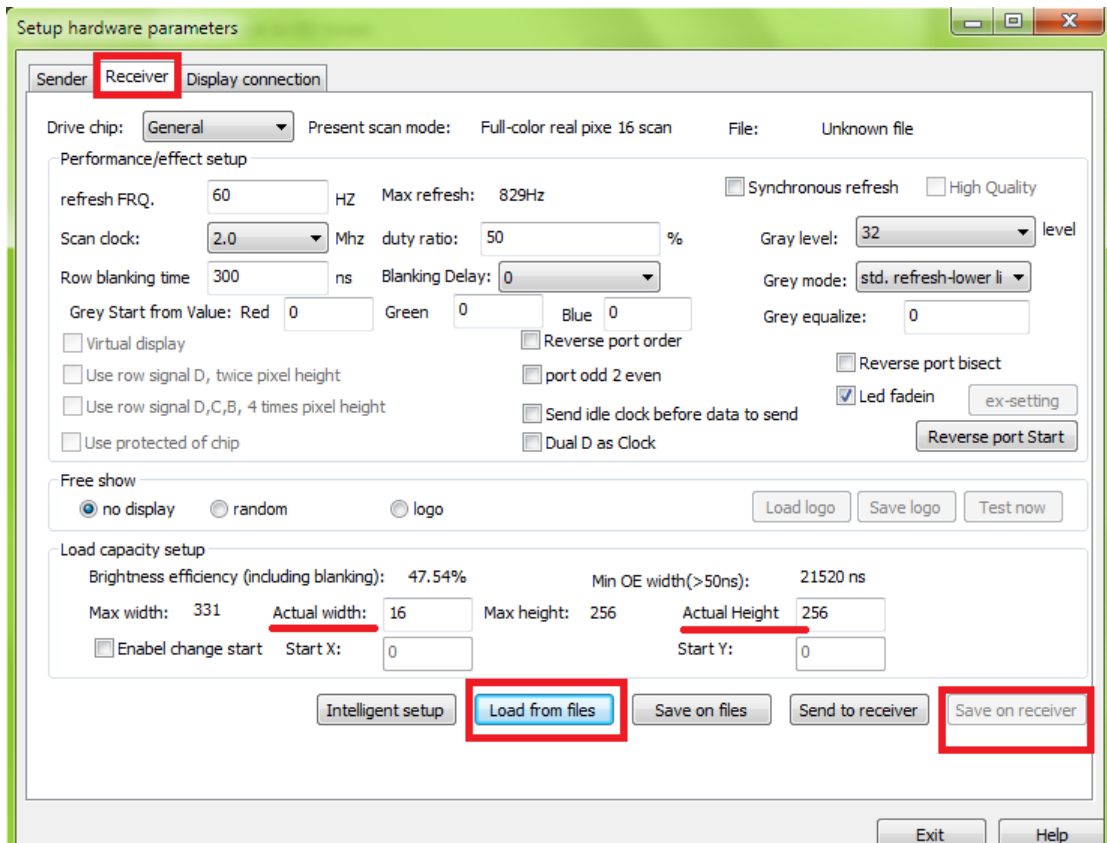

3. Upload the **CORRECT \*.CON** file from **Display connection** tag, by **Load from file**  
 Or Configure the CON file in DISPLAY CONNECTION, send and save the CON file.

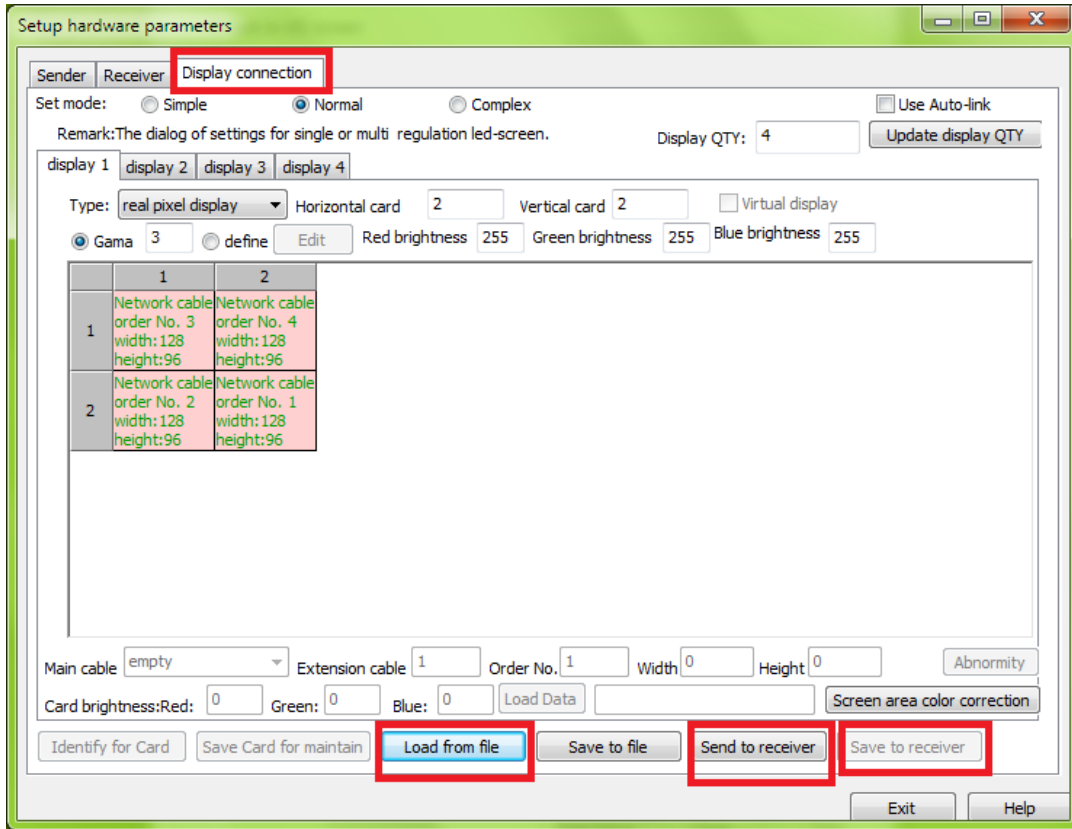

4. Manually change the **whole led display** or **single receiving card** RGB Value

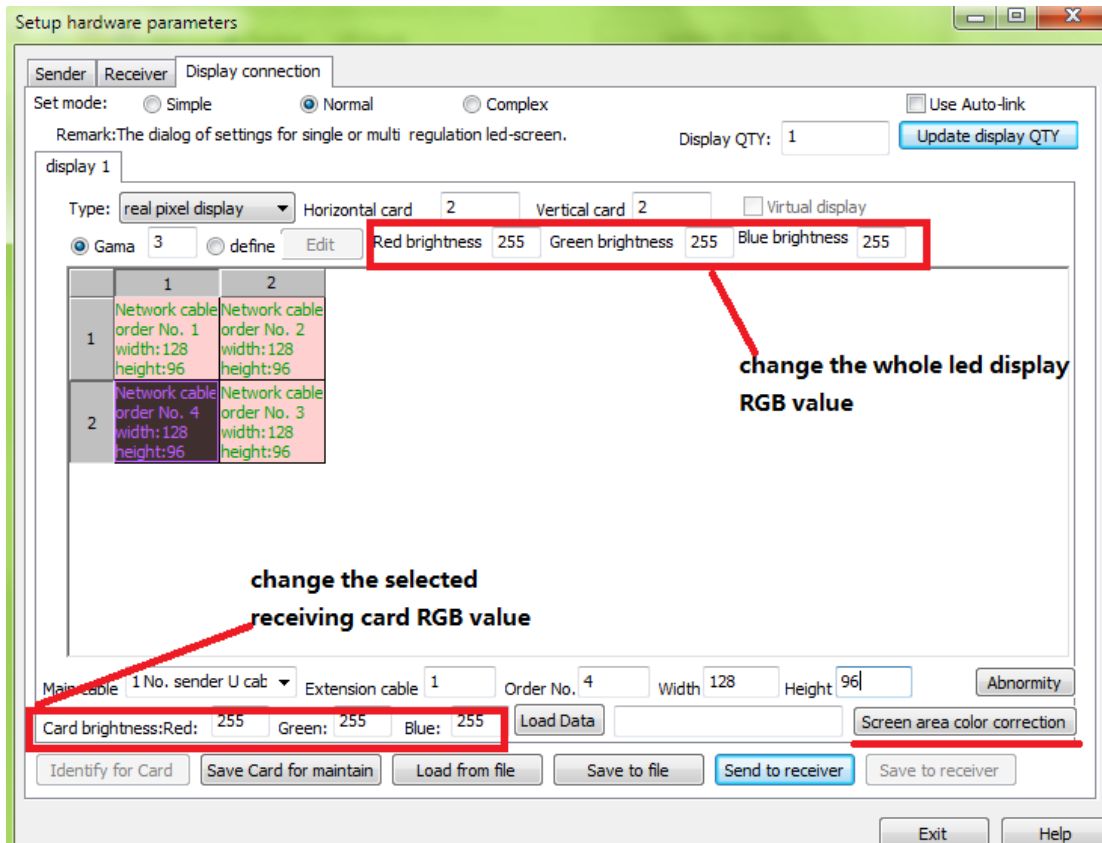

5. Change selected pixel(s) RGB value, Click **Screen area color correction**,

Select **adjust brightness**

Choose a correction mode from Software Single pixel, software2x2, software4x4, software8x8  
Extsoftware

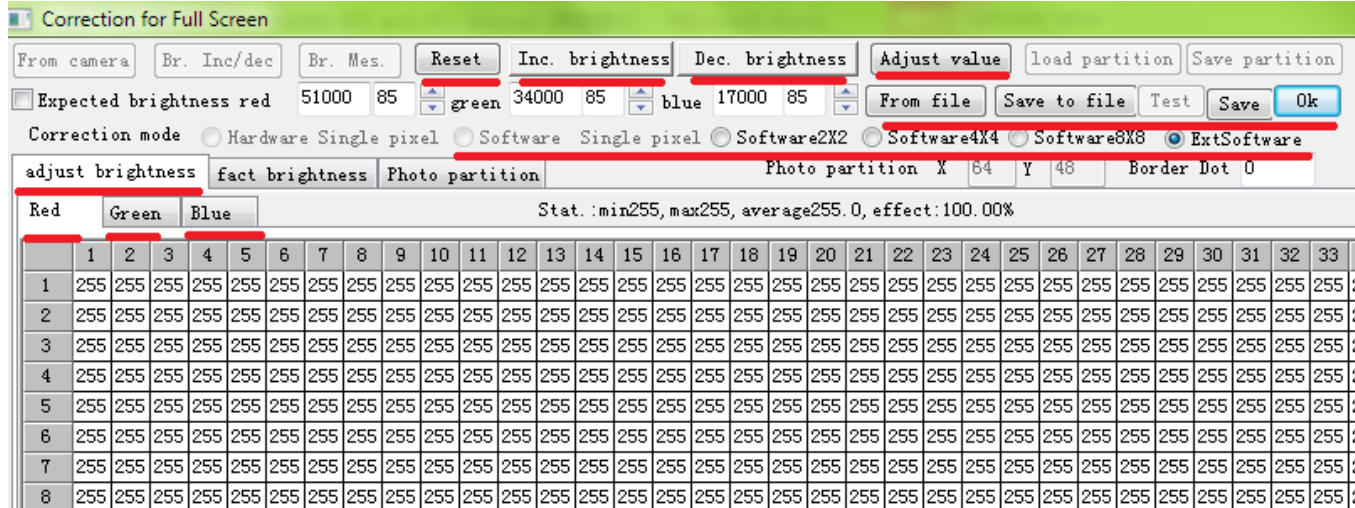

#### Details explanation

**Note:** hardware correction is to adjust the current of led display driver ic

**Single pixel:** pixel by pixel correction, choose this if one receiving card carries within 96\*64

**Software2X2:** take two neighboring pixels in width and 2 neighboring pixels in height as one correction unit

**ExtSoftware:** enhanced software brightness correction, one receiving card supports 320\*256 single pixel correction

Note: ExtsSoftware need firmware support. And different should select **Exsoftware** or (Single pixel/software2X2/software4X4/software8X8) accordingly

6. Select pixel(s) for adjustment

Select a color (Red/Green/Blue) to adjust

Click Inc. brightness/Dec. brightness/Adjust value

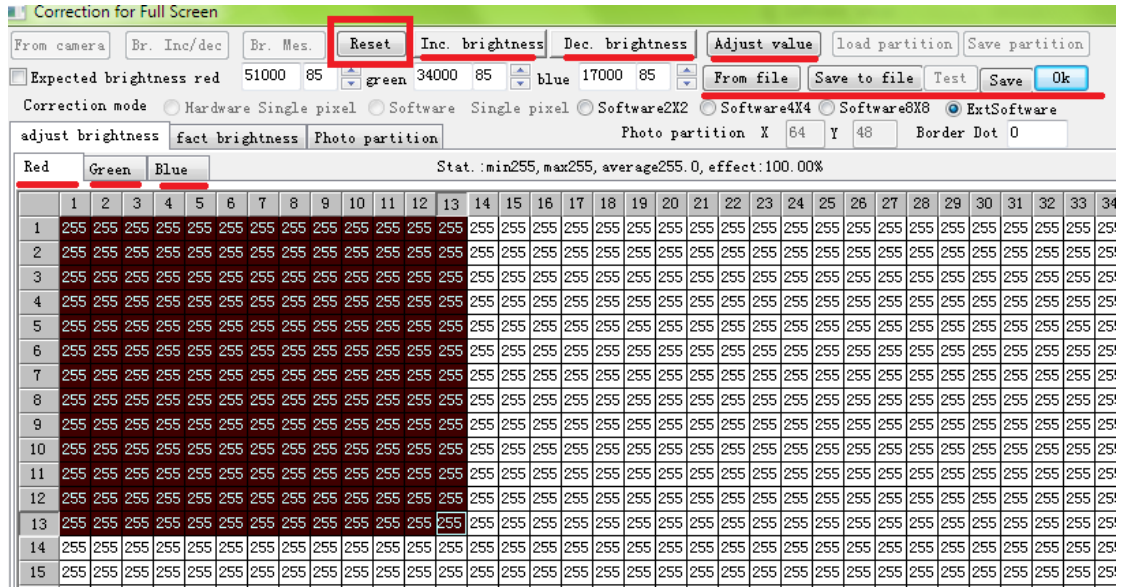

Inc. brightness: increase brightness

Dec. brightness: decrease brightness

Adjust value: change all pixels with Old Brightness Value to a New Brightness level

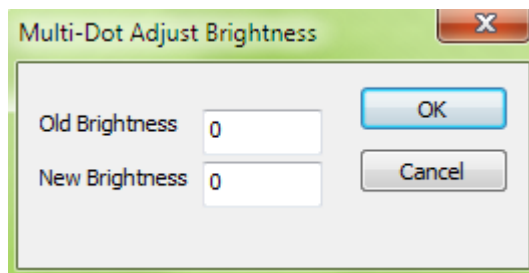

From file: load saved .RVS (correction info)

Save to file: after finishing manually brightness correction, save .RVS correction info to file.

Test: compare the effects with and without correction info

Save: save the .RVS file (correction info) in the flash memory of receiving card

7. Click **Ok** to exit

## Chapter5 Communication Cable Making Method

568B

### RJ-45 Connector

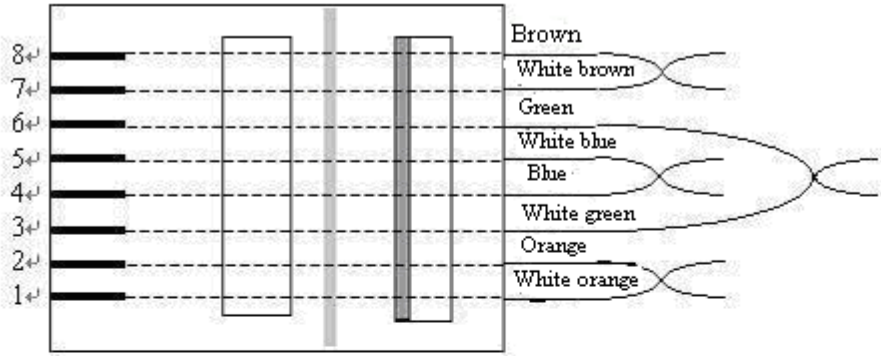

### RJ45 Connector TIA/EIA 568B Criterion

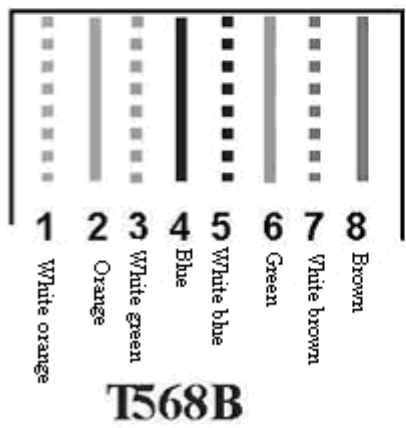

**Remarks: make the two ends same.**